

A P P E N D I X - B

ROARING FORK WATER & SANITATION DISTRICT

RULES AND REGULATIONS

April 2019

Prepared By:

Schmueser Gordon Meyer, Inc.
118 W. 6th St., Suite 200
Glenwood Springs, CO 81601

INDEX

		<u>Beginning Page</u>
I.	SUBMITTAL INFORMATION	B-3
II.	WATER TRANSMISSION AND DISTRIBUTION LINES	B-8
III.	WATER SERVICE LINES AND APPURTENANCES	B-13
IV.	FIRE PROTECTION FACILITIES	B-17
V.	VALVES	B-19
VI.	TRENCHING, BACKFILLING AND COMPACTION	B-22
VII.	PRESSURE TESTING AND FLOW TESTING	B-27
VIII.	DISINFECTION OF POTABLE WATER LINES	B-29
IX.	SPECIAL CONSTRUCTION	B-31
X.	BACKFLOW PREVENTION	B-35
XI.	SANITARY SEWERLINES	B-36
XII.	TRENCHING, BACKFILLING AND COMPACTION	B-53
XIII.	WATER DETAILS	
XIV.	SANITARY SEWER DETAILS	

I. SUBMITTAL INFORMATION

1.00 GENERAL

1.01 Scope. This section shall cover the required submittal material necessary for the Roaring Fork Water and Sanitation District to review a water and sewer project to ensure that it conforms to these regulations. Included in this section are the requirements on preliminary, final and as-built drawings, specifications, soils reports, and other supporting documents. Finally, this section will cover the submission and review procedures to be followed for the District. Upon request of a Developer, and after consultation with the District Engineer, the District may approve variances from the Technical Specifications and Procedures contained herein. See Rules and Regulations for procedures.

2.00 PRELIMINARY DRAWING REQUIREMENT

2.01 General. This section shall include the requirements necessary for preliminary drawing submittal, specifications, calculations and soils reports.

2.02 Title Sheet. The first sheet of the drawings shall be the title sheet and shall have the following shown thereon.

- A. Location map, North arrow, numerical and graphical scale.
- B. Index to sheet of the drawings.
- C. General notes.
- D. Title block. The title block should not include the words "Title Sheet," but should contain the project name and a description of the information shown thereon.
- E. Title sheet shall be stamped "Preliminary Not for Construction"

2.03 Plan. The following items shall be included on all plan drawings.

- A. Scale: *Use a maximum scale of one inch = 50 feet.* Show scale numerically and graphically.
- B. North arrow.
- C. Show outline of water and sewer main and service lines. Show centerline of water and sewer line with appropriate ties to centerline of street or survey control lines, curbs, property lines or right-of-way lines *and easement lines.* .
- D. Show right-of-way or easement lines, street centerline and name, property lines, curbs, gutters, cross gutters, sidewalks, driveways, paving and other improvements, existing and proposed.
- E. On each sheet of the plan, show a sufficient number of typical sections to give the relative location of surface and underground improvements with respect to proposed sewer main. Indicate size, type and other appurtenant data for all improvements.

F. Drawings shall be on standard 24 inch x 36 inch sheets.

G. Utilities, sewers and storm drains.

1. Indicate the type, size and ownership of all existing utilities in streets or rights-of-way or rights-of-way in which the water and sewer lines are to be connected. Tie utilities, sewers, house connections and storm drains to streets rights-of-way centerline or to street property line.
2. Indicate portions of existing utilities that are to be abandoned because of water and sewer construction.

H. Details. At intersections where tees, crosses, valves and concrete reaction blocks are to be provided, or at any other sections of the lines where a large number of fittings will be involved, show a large scale view of the appurtenances with dimensions to each separate fitting.

2.04 Calculations. One set of calculations supporting the design criteria used shall be furnished with the preliminary drawings. Each sheet of calculations shall be dated and have the name or initials of individual making the calculations. All calculations shall be by a professional engineer registered in the State of Colorado.

2.05 Soils Report. A soils investigation report shall be provided with the preliminary drawings. Sufficient subsurface exploration borings and analyses shall be made to permit the Roaring Fork Water and Sanitation District to make an adequate assessment of any soil problems that may be encountered. The soil investigation report shall contain the findings and supporting data for the following:

- A. The relative density type and extent of material to be encountered.
- B. Excavation problems.
- C. Location and extent of excavation.
- D. The suitability of excavated materials for use as backfill or bedding.
- E. The compaction characteristics of the soils.
- F. The groundwater level and conditions.
- G. The earth resistivity, moisture content, pH, degree of variation, presence of sulfates, and the likelihood of stray, direct currents.
- H. Test Holes. The depth of test holes shall be at least two feet below the proposed pipeline elevation. The spacing of test holes shall be a minimum of 600 feet or where unusual conditions exist. The spacing shall be such to adequately define soil.
- I. The soils report shall make recommendation on the consolidation, hydrocompaction shrinkage potential

2.06 Surveys. All the existing conditions, including rights-of-way easements and horizontal and vertical control information, shall be prepared by a registered land surveyor in the State of Colorado.

Roaring Fork Water & Sanitation District

3.00 SUBMISSION AND REVIEW PROCEDURE

3.01 Procedures. This section shall cover the procedures and time frame necessary to submit water and sewer drawings to the Roaring Fork Water and Sanitation District.

3.02 Preliminary Drawing Review.

- A. One set of blueprints and specifications, on paper and electronic format, of the proposed water and sewer system accompanied by one set of supporting data shall be submitted to the District at least 45 days prior to a regular meeting of the Board. The preliminary drawings and specifications of the proposed water and sewer system shall be reviewed in general and, if in acceptable form for processing, shall be referred by the District Administrator to the following offices and interested persons for study and recommendation at least 30 days prior to a regular Board meeting.
1. The District Engineer (SGM, Inc.)
 2. Garfield County
 3. Roaring Fork Water & Sanitation District

When transmitting the preliminary drawings and specifications for review, the District shall indicate to the reviewing agency the date and time of the District meeting at which the proposed water and sewer system will be discussed and formal action taken by the Board.

- B. At the regular meeting of the Board at which the proposed water and sewer system is to be considered, the Board shall review all written and oral recommendations presented and shall, upon diligent evaluation of the facts, approve or disapprove the preliminary plans for the proposed sewer system.
- C. Should the Board approve the preliminary plans, written notice of said approval shall be transmitted to the Applicant along with any modifications required by the District. Such approval of preliminary plans shall permit the Applicant to prepare final construction drawings in accordance with the standards established by the Board and incorporate any modifications required by the District.

3.03 Final Drawing Review.

- A. Final drawings and specifications shall be prepared in the form prescribed for preliminary drawing requirements. In addition, the title sheet shall provide a space for certification of construction approval by the Board of the Roaring Fork Water and Sanitation District.
- B. Final drawings consisting of four sets of prints, one set of drawings in electronic format and the AutoCAD file for the project shall be submitted to the Board for final review at least 10 days prior to a regular meeting of the Board.
- C. If the final drawings are found to be in compliance with the District's standards and these regulations and any modifications requested by the Board, the District

shall recommend approval of the plans at the next regular Board meeting.

- D. If the final drawings and specifications are found not to be in compliance with the District standards and any modifications requested by the Board, the District Engineer shall recommend disapproval of the plans and submit a written itemization of the deficiencies at the next regular meeting of the Board. Non-conformity of the final plans with the District's standards and requirements of the Board may result in disapproval of the project by the District.
- E. The Applicant is strongly advised against receiving construction bids or beginning construction until certification of approval of final plans and specifications has been received from the District.

3.04 Construction Procedures. Following final approval of the plan(s) by the District, the Applicant may proceed with construction. In addition, to all construction requirements contained in other portions of the Specifications, the Applicant and their Contractor shall observe the following:

- A. A mandatory pre-construction meeting shall occur 48 hours prior to any excavation. Participants may include, but are not limited to, the following: Representatives of the Contractor, Excavator, Engineer, Applicant and District.
- B. In the event that said construction does not commence within 6 months of the approval date, the plans must be resubmitted for review and approval. If construction on the main installation is halted for more than 6 months, plans must be resubmitted for review and approval.

3.05 Record Drawings. Two sets of record drawings, one set of drawings in an acceptable electronic format and the AutoCAD file of the project shall be submitted to the District within 30 days of completion of construction. The record drawings shall be prepared according to the following general requirements:

- A. A certified survey shall be provided to the District that shall show the location of the sewer line to permanent physical objects located in the field. All valves, tees, curb boxes, hydrants, storage tanks and pump stations and other major appurtenances shall be given two swing ties to a physical permanent object in the field. In all cases, the distance from sewer line and appurtenance items shall be dimensioned to rights-of-way easements and property lines.
- B. The benchmarks or benchmarks used on the project to determine sewer line depth shall be shown on the drawings and shall be based on U.S.G.S datum.
- C. All sewer lines shall have manhole rim and invert elevations, percent slope and horizontal distance of each line between manholes shown. Sewer service lines stubbed to property lines shall have two swing ties provided to permanent objects and shall be marked with fence posts.
- D. Manufacturer's literature and product data, including catalog sheets and descriptive literature for all materials and equipment used, shall be provided with record drawings.
- E. CADD files shall be submitted to the District in AutoCAD format, either on an

acceptable electronic media or e-mailed. Data shall contain GPS points that can be easily incorporated into the District's GIS database.

- F. All sewer main lines 8 inch or larger shall be televised. The video shall have a running footage meter showing the exact footage from the entry manhole. The video shall be provided with a log showing the location of all defects and service lines.

End of Section I

II. WATER TRANSMISSION AND DISTRIBUTION LINES

1.00 GENERAL

1.01 Scope. This section shall include all materials, labor, equipment and miscellaneous items necessary to install all raw water, potable water transmission and distribution pipelines and appurtenances as specified herein for the Roaring Fork Water and Sanitation District.

1.02 Protection of Work. All pipe, fittings, valves and equipment shall be carefully handled, stored and protected to prevent damage to materials, protective coatings and linings. At no time shall such materials be dropped or dumped into the trench.

Precautions shall be taken to prevent foreign matter from entering the pipe, fittings and valves prior to and during installation. No debris, tools, clothing or any other material shall be placed in the pipe during installation. Whenever pipe installation is suspended, either temporarily or overnight, the open end of the pipe shall be sealed with a watertight plug to prevent the entrance of trench water, debris or foreign matter into the pipeline system.

Under no circumstances shall trench water be allowed to enter the pipeline. When water is present in the trench, the plug shall remain in place until the trench is pumped dry. Whenever trench water becomes evident, measures shall be taken to prevent pipe flotation.

If, in the opinion of the Engineer, the Contractor is incapable of keeping the pipe free of foreign matter during installation, the Engineer shall require the Contractor to protect the pipe ends with water tight plugs until the start of the joining operation.

2.00 MATERIALS

2.01 General. This item covers the types of materials that will be required for the construction and installation of water lines. All materials used shall be new, of the best quality available, and conform to applicable standards as indicated herein.

2.02 Ductile Iron Pipe and Fittings.

A. Ductile Iron Pipe.

1. Reference Standard - ANSI, 21.51/AWWA C151, latest revision.
2. Thickness Class - Minimum Class 52 unless design conditions warrant higher-class pipe.
3. Pipe joints shall be push-on joints except where specifically shown or detailed otherwise.
4. Restrained joint pipe shall be Griffin Snap Lok or approved equal.

B. Fittings.

1. Type - All fittings shall be mechanical joint except where specifically shown or detailed otherwise.

2. Reference Standard - ANSI/AWWA C153 for flanged mechanical joint and push-on joints (3 inch - 24 inch).
 3. Material - Ductile iron.
 4. Pressure Rating - 350 psi.
- C. Joints.
1. Mechanical, Reference Standard - ANSI A 21.53/AWWA C153 (latest revision).
 2. Push-on, Reference Standard - ANSI A 21.52/AWWA C153, latest revision.
 3. Flanged, Reference Standard - ANSI B 16.1, Class 125, latest revision.
- D. Gaskets.
1. Type - Rubber ring gaskets shall be suitable for the specified pipe sizes and pressure.
 2. Reference Standard - AWWA C111, latest revision.
 3. Lubricant - A non-toxic vegetable soap lubricant shall be supplied with the pipe.
- E. Protective coatings – Refer to Detail 1.
1. Underground Service - Manufacturer's standard bituminous coating - minimum 1 mil thickness.
 2. Polyethylene Film Envelope - Polyethylene encasement shall conform to AWWA C105, latest edition, or ANSI A.21.5. Film shall be Class C with a nominal thickness of 8 mils. Tape for securing the film shall have a minimum thickness of 8 mils and a minimum width of 1 inch. The polyethylene film shall be free of streaks, pinholes, tears or blisters.
- F. Protective Lining.
1. Type - Cement mortar.
 2. Reference Standard -ANSI A 21.4/AWWA C104, latest revision.
 3. Thickness - Standard.

- G. Couplings.
 - 1. Style - Solid sleeve.
- H. Tracer Wire
 - 1. Tracer wire shall be 12 gauge or larger, insulated, stranded copper installed on all water mains. All splices shall be watertight and underground.

3.00 INSTALLATION

3.01 General. All transmission and distribution lines to be dedicated to the Roaring Fork Water and Sanitation District, shall be located a minimum of ten feet inside a public easement. The location of water lines within side lot line easements or rear lot easements is discouraged. Refer to Detail 11.

When site conditions allow, the water line should be located outside paved areas. At all times, water lines shall be located so that District maintenance personnel can easily maintain and operate those lines.

Easements or rights-of-way used during installation of water mains shall be a minimum width of 25 feet, 12.5 feet on either side of centerline. In dredge areas and other special conditions, a wider easement may be required.

3.02 Pipeline Depth. The minimum depth of bury of water mains shall be as follows: (Depth of bury equals depth to top of pipe).

- A. Mains shall be buried a minimum depth of 5.5 feet or 66 inches (below existing or proposed grade) in all locations.
- B. When water mains are to be located underneath storm drains, culverts or any other submerged air space, the required depth of bury shall be 5.5 feet deeper than crossing elevation. This is necessary to ensure that the water line is beyond the frost depth associated with the storm drain culvert, etc. In some cases, the District engineer may allow insulation in place of increased depth where water lines cross under one of the above.

3.03 Cleaning and Inspection. Clean all pipe, fittings, valves and related materials thoroughly of all foreign material; inspect for cracks, flaws, or other defects prior to installation. Mark all defective, damaged or unsound materials with bright marking crayons or paint and remove from job site. Of particular concern should be the gasket groove in the pipe bell. All spurs, excess paint, and any other defects within the gasket groove shall be either removed or repaired, or the pipe shall be deemed unacceptable.

The Contractor shall take all necessary precautions to prevent any construction debris from entering the water lines during construction of water lines and appurtenances. If debris shall enter the distribution system, the Contractor shall furnish all labor and materials necessary to clean the system. Under no circumstances will the Contractor flush the debris into an existing distribution system.

3.04 Installation. Pipe shall be laid in straight sections with bell ends facing the direction of laying unless otherwise directed by the District. Where pipe is laid on grade of 1% or greater, the installation shall proceed uphill with the bell ends facing upgrade. The pipeline shall be installed so that a continuous positive or negative grade is maintained between high and low points to avoid air pockets. At no time will a high point in the line be acceptable unless an air and vacuum valve is installed to relieve air pockets. Jointing of the pipe shall be made in accordance with the directions of the manufacturer of the pipe and the manufacturer of the couplings. The allowable pipe deflection per joint shall not exceed the maximum deflection tolerances specified by the manufacturer.

Pipe shall be lowered into the trench with ropes, slings or machinery. Under no circumstances should the pipe be pushed off the bank and allowed to fall into the trench.

In joining the pipe, the exterior four inches of the pipe end (at the spigot), and the inside of the adjoining bell shall be thoroughly cleaned to remove oil, grit, tar and other foreign material. The gasket shall be placed in the bell so it will spring into its proper position inside the pipe bell. A thick film of the non-toxic joint lubricant shall be applied over the entire surface of the gasket. The spigot end of the pipe shall then be wiped clean and inserted into the bell to contact the gasket. The pipe shall be pushed all the way into the bell by crowbar or by jack and choker slings. Extreme care shall be exercised when joining the pipe to avoid damaging the bell or rolling the gasket. The bell end of the pipe shall be protected by a piece of wood when pushing the pipe. Generally, every pipe has a depth of insertion stripe on the spigot end. The pipe shall be inserted to the full depth of the stripe. Check bells for rolled gasket with feeler gauge.

The cutting of pipe for fittings or closure pieces shall be done in a neat and workmanlike manner to prevent damage to the pipe or lining. All cuts should leave a smooth end at right angles to the axis of the pipe. Flame cutting on pipe, by means of an oxyacetylene torch, will not be allowed. Once a pipe is cut, the cut end shall be beveled free of spurs, which may damage rubber gaskets.

3.05 Connection to Existing Water Facilities. All main line connections between existing and proposed piping shall be made during non-business hours or at a time, which is acceptable to the District. All shut-offs shall be planned 24 hours in advance and all persons affected by the shut-off shall be given a 24-hour notice. Take all precautions to prevent contamination when making connections to existing potable water lines. No trench water, mud, or other contaminating substances shall be permitted to enter the pipeline.

3.06 Future Connections. At intersections, dead-end runs, or other locations where the possibility may exist for a future connection, a tee or cross and a valve should be provided. In addition, the stub out must extend to the property line. This procedure allows a future connection to be made while keeping the existing main line in service at all times. In each case, the valve shall be properly restrained to the tee or cross, using restraining rods with eyebolts. In addition, a concrete reaction block will be placed on the plugged end of the valve.

3.07 Protection of Water Supplies. Water lines shall be located a minimum of 10 feet horizontally from existing or proposed sewer mains. Wherever the sewer line crosses above or within 18 inches beneath the water lines, the sewer line shall be made impervious by any of the three methods listed below also refer to Detail 13:

- A. **Method 1.** Twenty feet of AWWA DR18 C-900 PVC, shall be used for sewer pipe and centered over the water main. The joints between the sewer pipe and the placement

Roaring Fork Water & Sanitation District

pipe (DIP or PVC) shall be encased in a concrete collar. The concrete collar will be a minimum of 1 foot thick, centered on the joint.

- B. **Method 2.** Twenty feet of AWWA DR18 C-900 PVC, shall be used for sewer pipe and centered over the water main. The joints between the sewer pipe and the placement pipe (DIP or PVC) shall be sealed with solid sleeves with transition gaskets.
- C. **Method 3.** The sewer pipe shall be reinforced with concrete encasement. The encasement shall be at least six inches thick on either side of the water main, and extend 10 feet each side of the water main. In all cases, select granular backfill shall be used to prevent any settling of the higher pipe.

All work should be in strict conformance with the Colorado Department of Health's "*Design Criteria for Potable Water Systems*".

3.08 Reaction Anchor and Blocking. Concrete thrust blocks shall be provided as shown in Detail 2 for all tees, elbows, plugs, reducers, valves, fire hydrants, and crosses if one or more sides of the cross are plugged. The bearing area of the block shall be at least equal to that stated on the attachment. The bearing surface shall be against undisturbed earth. The block shall be placed normal to the thrust as show on the drawings. Concrete for thrust blocks shall have a 28 day 3,000 psi compressive strength. (NOTE: No other materials other than concrete may be used in thrust blocks).

If the concrete has not had sufficient time to cure (e.g., restoring water service), the Contractor shall be required to use temporary bracing for added strength. Use of additional wood bracing will help prevent fitting and valves from leaking or "blowing off" when water pressure is restored to the main line.

Whenever a concrete thrust block is placed, wood or plastic sheets shall be used to prevent concrete from adhering to nuts and bolts. Any concrete splattering onto a nut or bolt will be removed before the line is backfilled.

3.09 Tracer Wire. Electrical tracing wire shall be required on all water mains. The wire shall be taped to the top of the pipe at 10 foot intervals to prevent dislocation of the wire during backfilling. The tracer wire shall be extended to the surface at all valves and fire hydrants. The wire shall be extended towards the ground on the outside of the valve box until the wire is within 4 inches of the top of the lid, at which point it shall be brought back inside the box and securely fastened. Sufficient slack in the outside of the wire shall be provided to compensate for any future adjustment to the valve box. The tracer wire shall be continuity tested prior to acceptance of the pipeline.

4.00 SIZING OF MAINS

4.01 General. All main water lines shall be sized for peak hour flow plus fire flows required by the Carbondale Rural Fire Protection District at a 20 psi residual flow. Minimum size shall be 8 inches in diameter.

End of Section II

III. WATER SERVICE LINES AND APPURTENANCES

1.00 GENERAL

1.01 Scope. This section shall include furnishing all materials, labor, equipment and miscellaneous items necessary to install all water service lines and appurtenances as specified herein for the District. Note: The District will own and maintain that portion of the service line from the main line up to and including the curb valve. The curb valve shall be placed on the property line; however, at all times, it will fall on the District side of the property line. All work and materials from the curb valve to the building shall be in conformance to the most recently adopted Uniform Plumbing Code.

2.00 MATERIALS

2.01 Copper Service Pipe.

- A. Reference Standard - ASTM B88, latest revision, Type K soft.
- B. Size - See 3.06 below.
- C. Do not use any pipe lubricants for service line fittings.

2.01 Eagle Pure Core HDPE Service Pipe.

- A. Reference Standard - AWWA C901, latest revision.
- B. Material - SDR9 CTS, HDPE 2408, ASTM D2239 and ASTM D2737.
- C. Size - See 3.06 below.

2.03 Corporation Stops.

- A. Material - Brass or bronze.
- B. Size - Same as copper service line.
- C. Reference Standard - AWWA C800, latest revision.
- D. Inlet - Threaded CC type.
- E. Outlet - Compression fittings.

2.04 Service Saddles.

- A. Materials - Bronze service clamp, 'O' ring gasket, double strap, IPS thread.
- B. The District will require saddles to be installed.

2.05 Curb Stop.

- A. Materials - Cast bronze body, resilient 'O' ring seals, standard tee head operator, Teflon ball valve type.
- B. Inlet - Compression fitting.
- C. Outlet - Compression fitting.
- D. Standard reference AWWA C800, latest revision.
- E. Manufacturer's reference - Mueller B25204.

2.06 Curb Box.

- A. 0.75 inch to 1 inch, Manufacturer's reference - Mueller H-10314 or equal.
- B. 1.25 inch to 1.5 inch, Manufacturer's reference - Mueller H-10336 or equal.
- C. Curb box must be traffic rated when located within traffic areas.

2.07 Couplings.

- A. Materials - Compression fittings.

3.00 INSTALLATION

3.01 Service Line Installation. All trenching, backfilling and compaction shall conform to Section VI of these regulations. All service lines shall be disinfected and pressure tested as per Sections VII and VIII of these regulations. Refer to Detail 3.

3.02 Service Line Depth. A depth of bury for all service lines shall be a minimum of 5.5 feet.

3.03 Tapping Pressurized Mains. All 0.75 inch – 1.5 inch taps on pressurized mains shall be made by the District. Those greater than 1.5 inches shall be performed by others with acceptable tapping equipment.

3.04 Tapping Unpressurized Mains. All taps on unpressurized mains (new subdivision mains) shall be performed by the District. Upon special request, District may allow Contractor to tap main.

3.05 Permits. A road cut permit for excavation in Garfield County streets, alleys and easements must be completed prior to tap. Forty-eight hour notice is required by the District prior to making taps and locating lines. Taps and locations will not be done without a water application filled out by Customer.

3.06 Service Line Sizing. Service lines are to be sized by Customer but the maximum copper service line allowed will be 1.5 inches. The maximum allowed HDPE service line will be 2 inches. The customer is encouraged to have an engineer size the service line. The District will not provide this service.

3.07 Tracer Wire. Electrical tracing wire shall be required on all service lines. The wire shall be taped to the top of the pipe at 10 foot intervals to prevent dislocation of the wire during backfilling. The tracer wire shall be extended to the surface at all curb stops. The wire shall be

Roaring Fork Water & Sanitation District

extended towards the ground on the outside of the curb box until the wire is within 4 inches of the top of the lid, at which point it shall be brought back inside the box and securely fastened. Sufficient slack in the outside of the wire shall be provided to compensate for any future adjustment to the curb box. The tracer wire shall be continuity tested prior to acceptance of the pipeline.

3.08 Final Inspection. The final inspection shall be scheduled with the District forty-eight hours in advance. The inspection will include inspection of the service connection, water meter, backflow device, rain sensor, curb valve and sewer cleanout.

4.00 METERS

4.01 Type. Magnetic drive, sealed register, radio read meter interface unit. Turbo meters for 3 inch and larger.

4.02 Manufacturer's Reference. Neptune T10 Brass Meter with E-coder and Radio Read MIU

4.03 Installation. Install all meters in a horizontal position with a suitable holding device to support piping, meter and provide electrical bond when meter is taken out for testing. Pre-manufactured holding devices or yolks are available which cut down labor time to install meter. Install in building where meter and pressure reducing valve will not freeze. Upon final inspection, if the meter is not able to be read by radio from the street, the MIU may need to be relocated on an outside wall at least six feet above grade where it is freely accessible and where falling or melting snow will not cover it (stucco construction can prevent the meters from being read by radio).

Turbine meters should be installed with five pipe diameters upstream or downstream of bends, valves, PRV's, check valves or any other fitting that causes turbulence.

4.04 Meter Inspection. The water meter must be inspected by the District at final inspection after it is installed and before the Certificate of Occupancy is issued.

5.00 PRESSURE REDUCING VALVE (PRV) (Required in-house)

5.01 Manufacturer's Reference. Watts U-5-B or equal.

5.02 Installation. Install upstream of the meter on 1 inch and 0.75 inch meters only. Install downstream of the meter for 1.25 inch and larger meters. Allow for easy access to strainer and cleanout plug.

5.03 Pressure Testing. Downstream pressure to be set at 40 to 75 psi.

5.04 Inspection. PRV will be inspected during final inspection.

6.00 CHECK VALVE

6.01 Type. Rubber seat and spring assist.

6.02 Manufacturer's Reference. Ford H series or equal.

7.00 BACKFLOW PREVENTION DEVICE

- 7.01 Type. Double check backflow preventer or as required by state law
- 7.02 Manufacturer's Reference. Febco
- 7.03 Installation. Backflow prevention device must be installed after the meter.
- 7.04 Inspection. Backflow preventer will be inspected during final inspection.

End of Section III

IV. FIRE PROTECTION FACILITIES

1.00 GENERAL

1.01 Scope. This section shall include furnishing all materials, labor, equipment and miscellaneous items necessary to install fire hydrants as specified herein for the Roaring Fork Water and Sanitation District.

2.00 MATERIALS

2.01 Fire Hydrants.

- A. Type - Dry barrel, traffic model with breakaway flange bolts and coupling.
- B. Reference Standard - AWWA C502, latest revision
- C. Outlet Size - One 4.5 inch NST, two 2.5 inch NST
- D. Hydrant Size – 5.5 feet or greater, from bury line to top of pipe
- E. Inlet Size - 6 inch
- F. Operation – 1.5 inch pentagonal national standard operating nut, open counter-clockwise, lubricating reservoir.
- G. Depth of Bury – 5.5 feet minimum
- H. Additional Requirements - Furnish hydrant complete with pipe and tee, 6 inch restrained mechanical joint gate valve and thrust blocks. Hydrant shall be restrained to the hydrant tee by 0.75 inch threaded rods protected from corrosion by the use of an approved bituminous coating. Furnish hydrant with bronze seat and lubrication reservoir. If the hydrant valve is located at the main then a 6 inch MJ x MJ swivel tee shall be used.
- J. Manufacturer's Reference - "Mueller" Centurion A423
"Kennedy" K-81A Guardian
- K. Color - Hydrant to be painted red above the bury line.
- L. Pressure Rating - 250 psi

3.00 INSTALLATION

3.01 Hydrant Spacing. The development density and type of development shall determine the spacing of fire hydrants that each hydrant is to serve. In a low-density residential area, the maximum spacing of fire hydrants shall not exceed 500 feet. In medium to high-density residential areas, the maximum spacing shall not exceed 400 feet. In commercial and high-risk areas, the spacing shall not exceed 300 feet. The maximum distance from commercial buildings to hydrants shall be 150 feet, and shall be based on hose length.

3.02 Location. Fire hydrants shall be located whenever possible at an intersection and in a public right-of-way or a utility easement. There shall be a minimum of 1.5 feet between outlet nozzle and back of curb or sidewalk. In all cases, hydrants shall be located out of the direct flow of pedestrian and vehicular traffic. Wherever possible, hydrants located consecutively along a street shall be placed on opposite sides of the street so that stringing fire hoses across a street during a fire can be kept to a minimum. Hydrants shall be placed at all intersections, at end of cul-de-sacs and at all dead-end runs. Hydrant location shall be approved by Carbondale Rural Fire Protection District.

3.03 Installation. The bury line shall be located at finished grade. If the previously mentioned conditions are not met after the hydrant is installed and the street is at final grade, the hydrant must be brought to proper grade by installing extensions or other modifications as required. Bag all hydrants that are not in service. If the hydrants have been accepted by the District and the hydrant needs to be raised due to Homeowner landscaping problems then the cost of the hydrant raising will be the responsibility of the homeowner. Refer to Detail 4.

3.04 Hydrant Appurtenances. All fire hydrants shall be connected to the main line by means of a mechanical joint tee with 6 inch Class 52 ductile iron pipe branch piping to hydrant. Each fire hydrant shall have a 6 inch valve on the branch pipe conforming to standards as outlined under Section V of these standards. The 6 inch gate valve shall not be located in the sidewalk, curb line, or gutter of the proposed street and shall be rodded to the main tee. Refer to Detail 4.

3.05 Hydrant Restraint. The hydrant shall be restrained to the main line with 0.75 inch all-thread rod extending from the main line tee to the 6 inch valve and then from the 6 inch valve to the hydrant. The 0.75 inch rods shall be tied to each joint with the use of eyebolts. A bitumastic coating (to prevent corrosion) shall be liberally applied to the all thread rod and eye bolts. In addition, the hydrant and main line tee shall be provided with concrete thrust blocks. Refer to Detail 2.

3.06 Dry Barrel Type Drainage. All hydrants shall be provided with a minimum of 0.33 cubic yard of 0.75 inch screened, crushed rock and shall be placed under the weep hole outlet to assure proper drainage. The crushed rock shall be encased in separator fabric to prevent the mitigation of fines. Prior to the screened rock being placed under the weep hole outlet, the area around the weep holes on the hydrant will be covered with plastic sheeting allowing enough room under the sheeting for the hydrant to drain and also preventing concrete from entering the weepholes.

3.07 Inspection. Prior to backfilling around the hydrant, a visual test shall be conducted to ensure the proper operation of the weep holes. The hydrant shall be partially opened and then closed. Water trapped in the hydrant barrel section should begin to drain. If water is not draining, the well holes should be cleared of any obstructions restricting the flow of water.

End of Section IV

V. VALVES

1.00 GENERAL

1.01 Scope. This section shall include furnishing all materials, labor, equipment, and miscellaneous items necessary to install gate valves, butterfly valves, air release and vacuum valves, and valve boxes as specified herein for the Roaring Fork Water and Sanitation District.

2.00 GATE VALVES

2.01 Materials.

A. Resilient seat.

1. Size - As shown on plans up to 12 inch (14 inch and larger shall be butterfly valves).
2. Reference Standard - AWWA C509, latest revision.
3. Style - Body, bonnet, and wedge: Cast iron, ASTM A126, Class B or Ductile iron, ASTM A536 Grade 65-45-12.
4. Pressure Rating - 200 psi.
5. Wrench Nut - Two-inch square, open by turning to the left (counter-clockwise).
6. Stem - Non-rising.
7. Manufacturer's Reference - Mueller.

2.02 Location. Whenever possible, water main valves shall be located at street intersections. Valves must be placed on all runs of a tee or cross. For instance, each cross shall have four valves located at the intersection while tees shall have three valves located at the intersection. Valves shall be located at the intersection. Valves shall be located at the end of all dead-end intersections for future connections.

2.03 Valve Spacing. Valves on cross-connecting or looped mains shall be spaced such that no single break shall require more than 500 feet of line to be out of service at one time. All distribution mains connecting to transmission mains must be valved at the tie-in.

2.04 Installation. All gate valves shall be installed with the 2 inch operating nut plumb and true with the vertical and centered within the valve box. District personnel will inspect the valve and valve box after installation to ensure that a valve key can easily be set on the operating nut. The operating nut shall be within 6 feet of finished grade or an extension must be provided attached to the nut. Refer to Details 5 and 6.

3.00 BUTTERFLY VALVES

3.01 Materials.

- A. Reference Standard - AWWA C-504, latest revision.
- B. Type - Rubber-seated, tight closing type.
- C. Ends - Both ends shall be mechanical joint for direct bury. Valves in vaults shall be flanged.
- D. Valve Body - Shall be high strength cast iron ASTM A 126, Class B with 18-8 type 304 stainless steel body seat.
- E. Operator - Valve operator shall be of the traveling nut type, sealed, gasketed and lubricated for underground service. Operating nut shall be two-inch square and shall open left (counter clockwise).
- F. Rated Working Pressure - Class 150B, 150 psi. Above 150 psi working pressure, use Class 250B or equal.
- G. Manufacturer's Reference - Mueller Line Seal III.

4.00 AIR RELEASE AND VACUUM VALVES

4.01 General. This specification covers all air release, vacuum valves or combination air release valves. The type of valve used shall be dependent upon the conditions under which it will operate.

4.02 Materials.

- A. Size - To be designed by Engineer for proper application.
- B. Body - Cast iron.
- C. Float - Stainless steel.
- D. Seat - Buna-N.
- E. Pressure Rating - 200 psi.

4.03 Locations. Air release, vacuum valves or combination air release valves shall be installed on transmission and long distribution lines to permit efficient filling or draining of long pipelines. In addition, they should provide protection against vacuum and shall continuously vent pockets of air accumulated in the pipeline. The type of valve shall depend upon the intended use of operation.

4.04 Installation. Air release, vacuum valves or combination release valves shall always be installed at the extreme high point of the distribution or transmission line. These valves shall be installed in a precast manhole vault with the fitting as shown in Detail 7.

5.00 VALVE BOXES

5.01 Materials.

- A. Material - Cast iron.
- B. Type - Three piece, screw type.
- C. Size – 5.25 inch diameter.
- D. Cover - Deep socket type with the word "Water" cast in the top.
- E. Base - No. 160 type with 20.5 inch wide oval base.
- F. Valve Markers - For valves that fall outside of road pavement and shoulders, install a 6 foot long, green "carsonite" marker or green metal "T" stake on all new valves. Marker shall have valve decal at top.

5.02 Installation. Valve boxes shall be installed plumb and true, and centered over the 2 inch operating nut. Bricks shall be placed under the flange of the valve box bottom so that at no time loadings on the valve box will be transmitted to the valve. Valve box lid to be placed 0.25 inch - 0.5 inch below grade when located in asphalt or concrete. A debris cap shall be installed as close as possible to the cast iron cap without interfering with the operation of the cap. Refer to Details 5 and 6.

End of Section V

VI. TRENCHING, BACKFILLING AND COMPACTION

1.00 GENERAL

1.01 Scope. This section shall include all labor, materials, equipment, and miscellaneous items necessary to perform all excavation, backfilling and compaction of underground waterlines and appurtenances as specified herein for the Roaring Fork Water and Sanitation District.

It shall be the Contractor's responsibility to secure all required excavation permits and pay all costs thereof.

1.02 Protection of Work.

- A. All excavation shall be protected by barricades, lights, signs, etc., as required by governing federal, state and local safety codes and regulations. Under no circumstances will more than 20 feet of trench be left open at night. Any trench left open at night will be protected by a temporary snow fence barricade and reflective tape.
- B. Sheeting, Shoring and Bracing - Where trench walls are not excavated at a stable slope, the Contractor shall provide and maintain sheeting sufficient to prevent caving, sliding or failure and property or bodily damage.

Under normal construction conditions, sheeting shall be removed as work progresses. Sheeting shall remain installed if directed by the District or if pipe does not have sufficient strength to support backfill based on trench width as defined by the sheeting.

The Contractor shall be held solely responsible for any violations of applicable safety standards. Particular attention is called to minimum requirements of OSHA and State of Colorado Occupational Safety and Health laws.

- C. Site Drainage - Excavation to be protected from surface water at all times.

2.00 MATERIALS

2.01 Embedment Materials. Pipeline embedment materials shall comply with the appropriate material as listed below and as illustrated in Detail 8.

- A. Class 6 Aggregate Base Course - Use for all distribution and transmission mains. In addition, use for all water service lines. Densely compacted 0.75 inch Class 6 aggregate, 4 inches below bottom of pipe with densely compacted 0.75 inch Class 6 aggregate to 12 inches above top of pipe.

2.02 Backfill Material.

- A. Characteristics - made of materials free from debris, organic matter from frozen material. Uniformly graded sufficient to allow proper compaction.

- B. No boulders greater than 6 inches in diameter in top 12 inches of backfill; bottom, 12 inches; or sides, 12 inches.

Generally, no boulder greater than 12 inches in diameter in remainder of trench.

3.00 METHODS AND PROCEDURES

3.01 Site Preparation.

- A. Clearing - Remove all vegetation, stumps, roots, organic matter, debris and other miscellaneous structures and materials from work site.
- B. Topsoil Removal - Strip existing topsoil from all areas to be disturbed by construction. Topsoil to be stockpiled separately from excavated materials.
- C. Pavement Removal - Asphalt and bituminous pavements to be cut to the full depth of pavement. The vertical face of the cut shall be a straight line parallel to the limit of excavation. Cuts shall be made with a flat-bladed air hammer, concrete saw, or as approved by the District Operator. The method used should provide a straight, true cut. All asphalt located within trench limits to be hauled off site.

Concrete pavements, including curbs, gutters and sidewalks, to be saw cut to the full depth of pavement at the nearest construction joint. The vertical face of the cut shall be a straight line parallel to the limit of excavation.

All pavement removal shall be disposed of off site. Broken pavement shall not to be used in backfill material.

3.02 Trench Excavation.

- A. Limits of Excavation - Trenches to be excavated along lines and grades as approved by the District. Trench widths for pipe loading shall be measured 12 inches above top of pipe.

Minimum trench width shall be the outside diameter of the pipe or conduit plus 16 inches.

Maximum trench width to be the outside diameter of the pipe or conduit plus:

- (1) 24 inches for outside pipe diameter of 24 inches or less.
- (2) 30 inches for outside pipe diameter of greater than 24 inches.

Trench excavation shall not to be completed more than 100 feet in advance of pipe installation. Backfill shall be completed within 20 feet of pipe installation by the end of any working day.

- B. Groundwater Control - Contractor to maintain facilities on site to remove all groundwater from trench. Water shall be kept at least 12 inches below the trench bottom, to a point such that a firm base for pipe or conduit installation exists. Facilities shall be maintained until all concrete is cured and backfilling is in

Roaring Fork Water & Sanitation District

place at least 24 inches above anticipated water levels before water removal is discontinued. All water removal shall be subject to approval by the District.

- C. Stockpile Excavated Material - Excavated material to be stockpiled so as to not endanger the work or public safety. Maintain existing vehicular and pedestrian traffic with minimum disruption. Maintain emergency access and access to existing fire hydrants and water valves. Maintain natural drainage courses and street gutters.

3.03 Bottom Preparation.

- A. Where soils are suitable and have adequate strength, bottom to be graded and hand-shaped such that the pipe barrel rests uniformly on embedment material.
- B. Bell Holes - Material to be removed to allow installation of all fittings and joint projections without affecting placement of pipe.
- C. Over-Excavation - Whenever trench is over-excavated to eliminate point bearing rocks or stones or when undisturbed grade tolerances of 0.1 foot is exceeded, the Contractor is to re-establish grade using aggregate bedding materials.
- D. Unstable Materials - Materials that are not capable of supporting super-imposed loadings are defined as unstable materials. Should unstable materials be encountered during excavation, immediately notify the District. If unstable material is encountered, the trench bottom shall be over-excavated (minimum 6 inches) and backfilled with clean 2 inch to 6 inch rock with filter fabric installed around it to prevent migration of fines. The rock backfill provides increased water movement and helps stabilize the trench bottom.
- E. Rock Excavation - Rock shall be removed to a 4-inch depth below in bottom pipe grading. Additionally, all rock loosened during jacking, blasting, etc., shall be removed from the trench.

3.04 Backfilling.

- A. Tamping Equipment - Except immediately next to the pipe, mechanical or air operated tamping equipment is to be used. Hand equipment, such as T-bar, is to be used next to pipe if necessary. Care is to be taken when compacting under, alongside and immediately above pipe to prevent crushing, fracturing, or shifting of the pipe. The Contractor is to note densities required for materials being backfilled and shall use appropriate approved equipment to obtain those densities.
- B. Moisture Control - Generally, maintain moisture of the backfill material within 2% of optimal moisture content as determined by ASTM D 698. Maintain close tolerances as needed to obtain densities required.
- C. Compaction - Maximum density (100%) based upon ASTM D698 or AASHTO T99.

- 1) Bedding Material. Includes material used for over-excavation of any kind: 95% Standard Proctor.
 - 2) Select Material: 95% Standard Proctor.
 - 3) Backfill beneath existing or proposed pavements, roadways, sidewalks, curbs, utility lines and other improvements or within 5 feet horizontally of such improvements 95% Standard Proctor.
 - 4) Backfill within public or designated right-of-way: 90% Standard Proctor or as shown on the Drawings for those areas outside of No. 3 above.
 - 5) Backfill within undeveloped, green or designated area: 85% Standard Proctor.
- D. Placing Backfill - The maximum loose lifts of backfill material to be as follows (use smaller lifts where necessary to obtain required densities):
- 1) Bedding and select material: 6 inches;
 - 2) Backfill Material: 12 inches where 95% compaction required; 24 inches where less than 95% compaction required.
- E. Maintenance of Backfill - Contractor to maintain all backfill in a satisfactory condition during the extent of the contract and warranty period. The Contractor will be responsible for repairing any deterioration or settlement of the road surface. The District will issue notification of the required repairs. All costs for repair and all liability, as a result of surface deterioration or settlement, shall be the responsibility of the Contractor.

3.05 Surface Restoration. All existing surface improvements and site disturbed or damaged during construction to be restored to a condition equal to pre-construction condition. All restoration costs are considered incidental to the excavation and backfill.

- A. Improvements - Replace, repair or reconstruct all improvements as required. Work will not be accepted until the District accepts restoration and all affected property owners. Improvements include, by example, other utilities, culverts, structures, curb & gutter, mailboxes, signs, etc.
- B. Roadways - All roadways to be restored to original condition with the following minimum depths required:
 - 1) Minimum base course material on gravel roadways or minimum depth gravel on hard surface roadways to be 12 inches.
 - 2) Minimum bituminous surfacing to be 3 inches.
 - 3) Minimum concrete paving to be 6 inches.
- C. If any pavement, street, shrubbery, sod, rock, fences, poles or other property surface structures have been damaged, removed or disturbed by Contractor or subcontractor of Contractor, whether deliberately or through failure to employ standards, such property and structures shall be replaced or repaired to the

District's satisfaction, at the expense of the Contractor.

4.00 QUALITY CONTROL - FIELD

4.01 Compaction. It should be fully understood that it will be the sole responsibility of the Contractor to achieve the specified densities for all embedment and backfill materials placed. Contractor will be responsible for ensuring that correct methods are being used for the placement and compaction of said materials. Correct backfill methods include, but are not limited to:

- A. Use of proper equipment for existing soil condition encountered.
- B. Moisture content of existing soils; determination if water should be added or if soil should be air-dried to reduce moisture content.
- C. Thickness of backfill lift.

Contractor may, at their own expense, have an approved geotechnical engineer monitor the methods of backfill and compaction used to ensure that the desired densities are being obtained.

4.02 Inspection and Testing. Inspection and testing to be performed at the direction of the District. Contractor to cooperate fully with all persons engaged in testing. Contractor shall excavate as required to allow testing. Contractor shall backfill all test excavations in accordance with these regulations.

4.03 Density Testing and Control.

- A. Reference Standards - Density/moisture relationships to be developed for all soil types encountered according to ASTM D698 or AASHTO T99.
- B. Field Testing - Testing for density during compaction operations to be done in accordance with ASTM D2922 using nuclear density methods.
- C. Frequency of Testing - Minimum of one (1) test for each 100 feet of trench or as directed by the District. Contractor to excavate to depths required by Engineer for testing and backfill test holes to density specified. Testing to be paid for by the Contractor.

End of Section VI

VII. PRESSURE TESTING AND FLOW TESTING

1.00 GENERAL

1.01 Scope. This section shall include furnishing all materials, labor, equipment and miscellaneous items necessary to perform pressure and leakage tests all distribution, transmission and service lines as specified herein for the District.

1.02 Hydrostatic Tests. Pressure and leakage tests shall be conducted on all newly laid pipe and service lines. Contractor to furnish all the necessary equipment and materials to conduct the test. Contractor shall test through fire hydrants if possible and will be responsible for installing the appropriate taps as approved by the District engineer if a hydrant is not available used.

The test shall be conducted between valved sections of the pipeline, or as approved by the District. Water service lines will be tested up to the closed curb stop. A visual inspection of the water service connection, at the water main and at the curb stop, will be performed to check the leakage; thus, Contractor shall not backfill the corporation and curb stop connections until inspection by District representative has been completed and accepted.

Furnish the following equipment and material for the tests:

<u>Amount</u>	<u>Description</u>
2	Approved graduated containers.
2	Pressure gauges.
1	Hydraulic force pump approved by the District.
1	Additional 0.75 inch pressure tap for District's gauge.
1	Suitable hose and suction pipe as required.

Conduct the tests after the trench has been backfilled or partially backfilled with the joints left exposed for inspection, or when completely backfilled, as permitted by the District. Where any section of pipe is provided with concrete reaction blocking, do not make the pressure tests until at least 5 days have elapsed after the concrete thrust blocking is installed. If High-Early cement is used for the concrete thrust blocking, the time may be cut to 2 days.

Conduct pressure test in the following manner unless otherwise approved by the District: After the trench has been backfilled as specified, fill the pipe with water, expelling all air during the filling. The test pressure shall be 1.5 times normal static system working pressure of the pipe at the point of lowest elevation (test minimum 150 psi).

A. Duration

1. The duration of each pressure test shall be two hours, unless otherwise directed by the District.

B. Procedure

1. Slowly fill the pipe with water and allow to stand for 24 hours. Expel all air from the pipe. Apply and maintain the specified test pressure by continuous pumping in necessary for the entire test period. The test pressure shall be calculated for the point of lowest elevation, or as specified by the District. The pump suction shall be in a barrel or similar device, or metered so the amount of water required to maintain the test pressure may be measured accurately.
2. Before the line is pressurized, the District shall verify that all the necessary main line valves are open or closed with regard to the section of line being tested. In addition, the District shall verify that all hydrant valves are open.

C. Leakage

1. Leakage shall be defined as the quantity of water necessary to hold the specified test pressure for the duration of the test period. No pipe installation will be accepted if the leakage is greater than the number of gallons per hour as determined by the following formula:

$$L = \frac{SD\sqrt{P}}{148,000}$$

In the above formula:

L = Allowable leakage, in gallons per hour.

S = The length of pipe being tested, in feet.

D = Nominal diameter of pipe, in inches.

P = Average test pressure during the leakage test, in pounds per square inch gauge.

D. Correction of Excessive Leakage

1. Should any test of pipe laid disclose leakage greater than that allowed, locate and repair the defective joints or pipe until the leakage of a subsequent test is within the specified allowance.

E. Flow Test

1. After new main has been leak tested, the line shall be flushed by opening 1 or more fire hydrants for approximately 10 minutes or until sediment has been flushed from system.

End of Section VII

VIII. DISINFECTION OF POTABLE WATER LINES

1.00 GENERAL

1.01 Disinfection. The following procedure shall apply to all main extensions within the District service area. Pipe extensions shall be chlorinated in accordance with AWWA C600 and C651 *Standard for Disinfecting Water Mains*.

THE CHLORINATION OF THE FINISHED PIPELINE SHALL BE DONE PRIOR TO THE INSTALLATION OF ANY SERVICE TAPS.

Before filling the pipe with water, the pipe shall be clean and *free of debris* to the satisfaction of the District.

The District shall perform disinfecting by chlorination of the pipe prior to acceptance. The chlorinating agent and method of application shall be in accordance with AWWA C651. The Contractor shall provide material for disinfecting of water mains.

If the tablet method of chlorination is used, during construction, calcium hypochlorite granules shall be adhered, with a CDPHE approved adhesive, to the inside top of every stick of pipe. The quantity of granules shall be as shown in the table below. This method may be used only if the pipes and appurtenances have been kept cleaned and dry during construction. This method is **not be used** on solvent welded plastic or on screwed joint steel pipe because of the danger of fire or explosion from the reaction of the joint compound with the calcium hypochlorite.

65% CALCIUM HYPOCHLORITE GRANULES

To be placed at the beginning of main and at each 500-foot interval.

<u>Pipe Diameter</u>	<u>Ounces</u>
4"	0.5
6"	1.0
8"	2.0
12"	4.0
16" and larger	8.0

After the pipe is filled with water and chlorine, and unless approved otherwise by the District, the chlorinated water shall be held in contact with the pipe for 24 hours. At the end of the 24-hour period, the water in the pipeline shall be tested by the District to ensure residual chlorine content of not less than 25 mg/l. The pipeline shall then be tested by the District thoroughly flushed to remove the heavily chlorinated water and/or debris. Care shall be taken in flushing the pipeline to prevent property damage and danger to the public. Discharge of highly coordinated water shall not be released to any stream or watercourse. Samples of water will be collected for bacteriological examination and residual chlorine content testing before the pipeline is put into service. The District will do testing of residual chlorine and bacteriological sampling and testing.

If the continuous feed method of chlorination is used, the Contractor is to provide the written

procedure to the District Inspector for acceptance of the method at least 48 hours prior to starting the work.

No main that has been disinfected and flushed shall stand stagnant for more than 15 days without being reflashed and a new disinfecting test performed, passed and approved by the District. **No main shall be tapped until the main has been flushed of all highly chlorinated water.**

1.02 Discharging Chlorinated Water. Contractor or Developer shall not discharge chlorinated water to any water body until the chlorine is neutralized and eliminated.

End of Section VIII

IX. SPECIAL CONSTRUCTION

1.00 GENERAL

1.01 Scope. This section shall include the design and construction of aerial crossings, river crossings, storage tanks, pressure reducing vaults and booster stations. Because each of these structures will require an engineered design to meet field conditions and individual design criteria, this section will not attempt to provide complete design guidelines and specifications. Rather, it will provide a general listing of guidelines that must be followed unless the District approves an equivalent alternative.

2.00 AERIAL CROSSING

2.01 General. This section shall cover the design criteria to be used on aerial crossings, including water lines suspended from existing and proposed bridges, and lines aerially supported over steep canyons and arroyos. In both of the above crossings, an underground or river crossing will be required unless special circumstances render the below grade alternative prohibitive. If it is determined that a bridge crossing is acceptable to the District, and then the following design criteria shall be followed.

2.02 Pipe Supports. If pipe is to be supported from an existing bridge, a structural analysis shall be performed to determine if the bridge can withstand the additional loading. If being installed on a new bridge, then additional pipe loading should be included as a dead load consideration.

Pipe shall be supported with a pipe hanger that allows longitudinal movement. Support shall be an adjustable steel yoke pipe roll or approved equal. In addition, a horizontal support from pipe hanger to the bridge shall be provided so that the pipe assembly will not move horizontally due to wind loads, etc. The spacing of the pipe hangers shall depend upon the maximum recommended load of hanger.

2.03 Pipe Insulation. Aerial pipelines shall be prevented from freezing by pipe insulation. The insulation R-value and thickness shall be designed to a generally accepted standard for the Roaring Fork Water and Sanitation District area. The insulation should have a minimum R-value of 20. The insulation shall be non-absorbing to water.

2.04 Insulation Protection. Provide an aluminum jacket with moisture barrier strapped with stainless steel bands. Jacketing thickness shall be a minimum of 16 mil. Provide insulation protection shields.

2.05 Pipe. Provide Class 52 ductile pipe with flanged joints, ANSI A.21.15, AWWA C 115, latest revision.

2.06. Expansion Coupling. Provide a restrained expansion coupling between each rigidly supported point of the pipe. Follow all manufacturer's recommendations when installing. Expansion couplings shall be accessible to water department personnel for maintaining and making adjustments in couplings.

2.07 Air and Vacuum Vaults. If bridge crossing is at a high point in line, install all air and

Roaring Fork Water & Sanitation District

I:\1996\96059\A-02 Rules and Regulations\2019\Appendix B - April 2019.doc

Rules and Regulations Appendix B

APRIL 2019

B - 31

vacuum valves appropriate for design conditions.

2.08 Isolation Valves. An isolation valve shall be provided on either end of the bridge. If a break occurs, the line can be easily isolated.

2.09. Accessibility. Generally, the pipe should be placed in a location where personnel can easily access and maintain the pipe.

3.00 RIVER CROSSINGS

3.01 General. This section covers the design criteria to be used on river crossings.

3.02 Encasement. Pipe shall be encased in concrete for the length of pipe underneath high water mark.

3.03 Pipe. For river crossing, the pipe joints shall be push-on joints with joint restraint, Class 52 D.I.P. Manufacturer's reference - Griffin Snap-Lok pipe or approved equal by District Engineer.

3.04 Bend Restraint. All vertical bends shall be restrained with vertical reaction blocks and all thread rods between bends or between bends and concrete thrust tie.

3.05 Permits. Generally, a river crossing will require a 404 Permit or Nationwide Utilities Permit from the Army Corps of Engineers. The Applicant should begin the permit process as soon as possible, as the process can take from 30-90 days to secure the permit.

4.00 STORAGE RESERVOIRS

4.01 General. This section covers the design criteria to be used on storage reservoirs. The District may allow either a buried concrete or aboveground steel reservoir. The District reserves the right to require either a concrete or steel tank depending on the field conditions, size and location of the tank. The District shall determine the size and location of the storage tanks.

4.02 Foundation Design. A soil and geological report shall be provided which makes recommendations on the required foundation.

4.03 Structural Design. Complete structural design, with calculations and shop drawings submitted by a professional engineer shall be provided. If a welded steel tank is provided, it shall conform to AWWA D100, latest revision.

4.04 CDPHE Requirements. All Colorado Department of Public Health and Environment, Water Quality Control Division "Design Criteria for Potable Water Systems" shall be followed.

4.05 Flow Measuring. A magnetic flow meter capable of measuring flow in both directions shall be provided. Two remote recording charts with totalizers shall be provided at the District office. The flow meter shall be housed in a vault outside the tank. The vault shall conform to the same basic requirements as a PRV vault (see Section 5.00 of this section). The vault shall contain heat, lights and two 110-volt outlets. Install lightning arresters on mag meter power sensor lines to eliminate surge and transient voltages (located at both ends).

4.06 Tank Insulation. Not Applicable.

4.07 Steel Tank Painting. Use an AWWA approved paint system for tank interior and exterior coating on all steel tanks. Painting shall conform to AWWA D102, latest revision.

5.00 PRESSURE REDUCING VAULTS (PRV) – Detail 9

5.01 General. This section shall cover the design criteria to be used on pressure reducing vaults. The District shall determine the location of PRV's.

5.02 PRV Valve. The PRV valve shall be a Clayton valve as manufactured by the Cla-Valve Company. The main valve shall be a single seated, hydraulically operated, pilot controlled, diaphragm-type globe valve.

5.03 Pilot Control System. Cast bronze ASTM B62 with 303 stainless steel trim. Install isolation cocks, closing and opening speed control and strainers on pilot controls.

5.04 Pressure Gauges. Install two stainless steel, liquid-filled, hermetically sealed pressure gauges with pressure snubbers, and isolation cocks. Locate at main inlet and outlet of vault so that if one PRV is isolated, gauges will still register.

5.05 Bypass Piping. Install a bypass around main PRV valve so that mainline can be filled and service maintained with PRV valve out of service. Bypass shall be installed with an isolation valve.

5.06 Pressure Relief Valve. If damaging downstream pressure can result when PRV is stuck in open position, then a pressure relief valve shall be installed on downstream side of PRV on either the main line or bypass line. Pressure relief valve shall be piped to daylight.

5.07 Isolated Valves. Install isolation resilient seat gate valves inside of vault so that main PRV valve can be isolated.

5.08 Air Release. Install an air release and vacuum valve on both inlet and outlet of pipe in vault. Each air release valve to have an isolation valve.

5.09 PRV Vault. All valves, appurtenances and pipe to be enclosed in a concrete or steel vault. Install link seal or equivalent between pipe inlets, outlets and vault wall. Provide frost-proof aluminum manhole lid marked "Water" on concrete vaults. Plastic covered steel MH rungs shall be provided on concrete vault with the first step not being greater than 18 inches from finished grade. Install concrete supports under PRV and tees. All vaults to be provided with one 110-volt outlet and a drain that daylights.

5.10 Fittings. All main line fittings shall be ductile iron flanged fittings.

6.00 Waterline Insulation – Detail 11

6.01 General. This section shall cover the installation to be used on water lines when insulation is required. The District engineer will approve the use of insulation on waterlines if the conditions will not allow the waterline to be buried deep enough to obtain 5.5 feet of depth below the lowest storm drain pipe.

6.02 Installation. In areas where 5.5 feet of depth is unable to be obtained between the waterline and the lowest storm drain pipe insulation can be approved by the District

Roaring Fork Water & Sanitation District

engineer. The insulation shall encase the waterline 4 feet in either direction of the crossing. Four inch thick polystyrene (Blue board) shall be installed 1 foot away from the pipe on both sides and the top. Contractor shall provide a minimum of 18 inches between the top of the insulation and the invert of the storm drain.

7.00 Transmission Line Tapping – Detail 12

7.01 General. This section shall cover the installation of a distribution line water tap onto a pressurized transmission main.

7.02 Installation. Tapping a pressurized transmission main for a new distribution line will only be allowed when the transmission line can not be shut down to install a traditional Tee and 3 valves. Pressurized taps will only be performed by contractors approved by the District. Tapping sleeve shall be stainless steel to prevent corrosion and shall be covered with 4 mil polyethylene plastic with a 0.75 inch tap for pressure testing. Gate valve shall be flange by MJ with a mega-lug or approved equal and with standard valve box as shown in Detail 5. A Thrust block shall be installed behind the tapping sleeve and shall be sized according to the Detail 2 for a Tee of 250 psi or less.

7.03 Testing. Tapping sleeve shall be air tested to gate valve with 1.5 times normal working pressure or 150 psig; whichever is greater for 5 minutes.

7.04 Manufacturer's Reference. Cascade CST - EX

8.00 Pipe Jacking/Boring – Details 14 – 15

8.01 General. This section shall cover the installation of utilities within a pipe casing that has been jacked or bored. Refer to Details 15 and 16 for design and installation details.

9.00 Water Meter Vault – Detail 16

9.01 General. This section shall cover the design criteria to be used on water meter vaults. Refer to Detail 16 for water meter vault details.

End of Section IX

X. BACKFLOW PREVENTION

1.00 GENERAL

1.01 Scope. This section shall include the use of backflow prevention devices to prevent cross connection.

1.02 Requirements. All work within the District must comply with the current requirements under Colorado law for prevention of cross connections and backflows. Such laws include, but are not limited to, Colorado Department of Health Statutes, C.R.S. ' 25-1-114(h); Colorado Primary Drinking Water Regulations, S.C.C.R. 1003-1 (Article 12); and the "*Colorado Department of Health Cross Connection Manual*".

In general, the law states that it is illegal to have or to maintain a cross connection on a public water supply. Cross connection is defined as any connection which would allow water to flow from any pipe, plumbing fixture or water system into a water system supplying drinking water to the public.

1.03 Public Education. The Roaring Fork Water and Sanitation District will educate system users about the potential health risk that cross-connections pose, with an emphasis on cross-connections. Contact the District Administrator regarding public education.

1.04 Types of Cross Connections. The following are common (but not limited to) cross connections and required devices to prevent backflow:

- A. Hose bibs - Vacuum breaker
- B. Irrigation lines/systems
- C. Fire sprinkler systems
- D. Boiler systems
- E. Dishwashers
- F. Solar homes using potable water as heat source
- G. Any building over 3 stories tall

1.05 Backflow Preventers. Be advised that each cross connection will require different types of backflow prevention devices, and is beyond the scope of these regulations. District personnel must give approval of backflow preventers.

1.06 Annual Testing. Article 12 requires that backflow prevention devices be tested annually by a certified backflow prevention technician. Contact District Operator for a list of certified backflow prevention technicians.

End of Section X

XI. SANITARY SEWER LINES

1.00 GENERAL

1.01 Scope. Work under this section shall include furnishing all materials, labor and tools necessary to perform all installation, cleaning and testing of all sanitary sewer lines and appurtenances as specified herein and shown on the Drawings.

1.02 Protection of Work. All pipe, fittings and equipment shall be carefully handled, stored and protected in such a manner as to prevent damage to materials. At no time shall such materials be dropped or dumped into trench.

Precaution shall be taken to prevent foreign matter from entering the pipe and fittings prior to and during installation. Place no debris, tools, clothing or other materials in the pipe during installation.

At such time as pipe installation is suspended, either temporarily or over night, the open end of the pipe shall be sealed with a watertight plug to prevent entrance of trench water, debris or foreign matter. A mechanical-type fitting shall be used for this seal. At no time shall duct tape or any other tape be used for this seal.

Under no circumstances shall trench water be allowed to enter the pipeline. When water is present in the trench, the seal shall remain in place until such time the trench is pumped dry. Whenever trench water becomes evident, adequate measures shall be taken to prevent pipe flotation. Contractor shall bear all costs associated with keeping trench free of liquids.

If, in the opinion of the Engineer, the Contractor is incapable of keeping the pipe free of foreign matter during installation, the Engineer shall require the Contractor to protect the pipe ends with water tight plugs until the start of the joining operation.

2.00 MATERIALS

this item covers the types of materials that will be allowed for the construction and installation of sewer lines. All materials used shall be new, of the best quality available and conform to applicable standards as indicated herein.

2.01 Ductile Iron Pipe and Fittings. Not permitted for gravity lines.

2.02 Polyvinyl Chloride (PVC) Pipe and Fittings (Gravity Main)

A. PVC Pipe, through 15 inch diameter.

1. Material Reference Standard - ASTM D1784
2. Pipe Reference Standard - ASTM D3034
3. Class – SDR-35
4. Markings - Manufacturer's name, nominal size, PVC classification, Type PSM, SDR-35, PVC gravity sewer pipe, ASTM D3034 and code number, green coloring dyed into PVC.

B. PVC Pipe, 18 inch to 27 inch diameter.

Roaring Fork Water & Sanitation District

1. Material Reference Standard - ASTM D1784
 2. Pipe Reference Standard - ASTM F679
 3. PS 46 PVC Sewer Pipe and ASTM F679. Green coloring dyed into PVC.
 4. Variance - PVC piping meeting the stiffness requirement of ASTM F679 but not meeting wall thickness requirement will be allowed under specification. Manufacturers will be required to provide a list of at least 5 similar projects with references in which pipe has been successfully used and laboratory testing data showing the pipe meets the structural requirements of ASTM F679.
- C. Restrained Joint PVC Pipe, through 16 inch diameter.
1. Material Reference Standard - ASTM D1784
 2. Class – SDR-32.5
 3. Manufacture’s Reference – CertainTeed - Certa-Lok Yelomine
 4. Markings - Manufacturer's name, nominal size, PVC classification, SDR-32.5, PVC gravity sewer pipe.
- D. Fittings
1. Type - PVC push-joint
 2. Materials - ASTM D1784
 3. Reference Standard - ASTM D3034 or ASTM F679
- E. Joints
1. Type - push-on rubber gasket
 2. Gasket reference standard - ASTM F477

2.03 Force Main

- A. PVC Pipe.
1. Materials - ASTM D 1784, Type 1, Grade 1, PVC 1120, 2000 psi design stress.
 2. Reference Standard - AWWA C-900.
 3. Class - 150 (DR-18), (or, dependent upon internal pressure, may require Class 200).
 4. Markings - Manufacturer's name, nominal size, class pressure rating, PVC 1120, NSF logo, identification code.
 5. Specialties - Electrical tracing wire, 14 gauge solid copper insulated wire.
 6. Size - Shall conform to outside diameter of DIP.
- B. Fittings.
1. Type - All fittings shall be restrained mechanical joint except where specifically shown or detailed otherwise. Fittings in a vault shall be flanged.
 2. Reference Standard - .AWWA/ANSI C153/A 21.53
 3. Pressure Rating - 350 psi

Roaring Fork Water & Sanitation District

4. Gasket Reference Standard - AWWA C-111
 5. Fittings shall be coated with Permafuse epoxy coating inside and out.
- B. Ductile Iron Pipe.
1. Reference Standard - ANSI 21.51/AWWA C151, latest edition.
 2. Thickness Class - 52
 3. Pipe joints shall be push on joints, except where specifically shown or detailed otherwise.
 4. Pressure Rating - 350 psi
- C. Fittings
1. Type - All fittings shall be mechanical joint.
 2. Reference Standard - ANSI/AWWA C153, latest edition, for mechanical "compact" joints.
 3. Material - Ductile iron
 4. Pressure Rating - 350 psi
 5. Fittings shall be coated with Permafuse epoxy coating inside and out.
- D. Joints
1. Mechanical, Reference Standard - ANSI A. 21.53/AWWA C153, latest edition.
 2. Push-on, Reference Standard - ANSI A 21.15/AWWA C115, Class 125.
 3. Flanged, Reference Standard - ANSI B 16.1, Class 125
- E. Gaskets
1. Type - Rubber-ring gasket for gravity main.
 2. Type - Rubber-ring Field-Lok gasket, or equal, for force main shall be suitable for the specified pipe sizes and pressure
 3. Reference Standard - AWWA C111, latest edition.
 4. Lubricant - A non-toxic vegetable soap lubricant shall be supplied with the pipe.
- F. Protective Coating
1. Underground Service - Manufacturer's standard bituminous coating - minimum 1 mil thickness.
 2. Polyethylene Film Envelope - Polyethylene encasement shall conform to AWWA C105, latest edition, or ANSI A.21.5. Film shall be Class C with a nominal thickness of 8 mils. Tape for securing the film shall have a minimum thickness of 8 mils and a minimum width of 1 inch. The polyethylene film shall be free of streaks, pinholes, tears or blisters.
- G. Protective Lining - Gravity Main
1. Type - Cement mortar
 2. Reference Standard - ANSI A 21.4/AWWA C104, latest edition.
 3. Thickness - Standard

H. Protective Lining - Force Main

1. Type - Lining designed for sewer service equal to Protecto 401 by Clow or Permafuse epoxy coating.

2.04 Small Diameter, Low Pressure Sewerline less than 4 inch.

A. Pipe Materials

1. High density Polyethylene pipe & fittings, HDPE 3408 Plastics Pipe Institute, DR9
2. Polyvinyl Chloride pipe (PVC) ASTM D-1784 & D-2241, DR21, 200 psi

B. Joints

1. Butt fusion for HDPE
2. Gasketed for PVC, 2 inch and larger; solvent weld for 12 inch and smaller.

C. Appurtenances

1. Air/Vacuum valve - Crispin SU20 sewage air/vacuum or approved equal
2. Isolation valve - PVC ball valve or approved equal.

2.05 Concrete for Thrust Blocks and Encasing of Pipe. Concrete for thrust blocks and for encasing the sewer pipeline shall have 28-day compressive strength of not less than 3000 psi.

2.06 Manholes. Details A, B, C, D

A. Concrete Rings/Cones

1. Type - Precast
2. Reference Standard - ASTM C478
3. Size - Four-foot or five-foot inside diameter

B. Manhole Bases

1. Shall be precast or cast-in-place, depending upon local jurisdiction standards, with integrally cast-in water stops. Tee tops of base shall be at least 12 inches above top of pipe.
2. Reference Concrete Standard – ASTM C478

C. Manhole Steps. Manhole steps shall conform to ASTM C478-94 and shall be steel reinforced copolymer polypropylene with materials conforming to the following:

Materials:

1. The deformed steel reinforcing bar shall be 2 inch conforming to ASTM A-615 Grade 60.
2. The copolymer polypropylene shall conform to ASTM D4101-92b

PP0344B33534Z02.

3. Manufacturer's Reference: M.A. Industries Model PS1-PF, or approved equal.

D. Joints

1. Type - Rub'r Nek preformed gasket as manufactured by K.T. Snyder Co., Inc, Houston, Texas, or equal.
2. Cement Mortar Material Reference Standard - One part Portland cement, Type II, modified with three parts of sand. Cement mortar to be used with concrete grade rings only.

E. Grade Adjustment Rings

1. Type - Precast ASTM C150 Type II modified concrete.
2. Size - Not less than 6 inch wide x heights to allow for two-inch adjustments.
3. Alternate - HDPE grade rings.
4. Manufacturer's reference: Ladtech, Inc., or approved equal.

F. Frame and Cover

1. Material Reference - Grey Iron, ASTM A48-83, Class 35B, traffic bearing.
2. Cover - Stamped with "SEWER", machined bearing surface with ring.
3. Type - Heavy, weight of cover greater than 140 pounds.
4. Manufacturer Reference -Castings MH-400-24CI.

2.07 Sewer Service Line Materials.

A. Full Body Wyes - Required for all new and existing sewer line construction.

1. Material - ASTM D3034 PVC
2. Strength - for use with SDR-35
3. Joint - Slip-on rubber gasket

2.08 Shear Gates. Not applicable.

2.09 Flap Gate. Not applicable.

2.10 Butterfly Valves. Not applicable.

2.11 Gate Valves. Not applicable.

2.12 Valve Boxes. Not applicable.

2.13 Tracer Wire. Tracer wire shall be 12 gauge insulated stranded copper wire. Tracer Wire shall be installed on all sewer mains and services. Wire continuity to be tested prior to pipeline being accepted.

3.00 METHODS AND PROCEDURES

3.01 Cleaning and Inspection. Clean all pipe, fittings and related materials thoroughly of all foreign material and inspect for cracks, flaws or other defects prior to installation. Mark all defective, damaged or unsound materials with bright marking crayon or paint and remove from job site.

The Contractor shall take all necessary precautions to prevent any construction debris from entering the sewer lines during construction. If this debris should enter the pipeline system, the Contractor shall furnish all labor and materials necessary to clean the system. Under no circumstances will the Contractor flush the debris into an existing sanitary sewer system.

3.02 Placement of Pipe.

- A. Laser Beam. All sanitary sewer pipes must be installed with a laser. If bending of the beam due to air temperature variations becomes apparent with "in pipe" units, a fan shall be provided to circulate air in the pipe. Air velocity shall not be so excessive as to cause pulsating or vibrating of the beam. If, in the opinion of the Engineer, the beam cannot be accurately controlled, this method of setting line and grade shall be abandoned.

3.03 Pipe Embedment. Detail E

- A. Placing embedment material - Refer to Section XII for placement methods.
- B. Embedment Classes - Refer to Section XII for embedment materials for each class listed below:
 - 1. Class A - Use of all PVC, DIP, CMP and Concrete pipelines.
 - 2. Class B - Use where indicated on the Drawings and where improper trenching or unexpected trench conditions require its use as determined by the Engineer.

3.04 Pipe Installation.

- A. Installation of Ductile Iron Pipe Lines. Not applicable.
- B. Installation of Polyvinyl Chloride (PVC) Pipe.
 - 1. Pipe Handling. Pipe should be carefully lowered into the trench to avoid pipe falling into trench.
 - 2. Pipe Laying. Pipe shall be laid true to line and grade, in an uphill direction, with bell ends facing in the direction of laying. When pipe laying is not in progress, a watertight plug shall close the open end of the pipe.
 - 3. Joining the Pipe. The outside of the spigot and the inside of the bell shall be thoroughly wiped clean. Set the rubber ring in the bell with the marked edge facing toward the end of the bell. Lubricate the spigot end using a thin film of the manufacturer-supplied lubricant. Push the pipe spigot into the bell. Position the completed joint so that the mark on the pipe end is

in line with the end of the bell.

4. Pipe Cutting. The cutting of pipe for manholes or for fittings, or closure pieces shall be done in a neat and workmanlike manner without damage to the pipe or lining and so as to leave a smooth end at right angles to the axis of the pipe. Bevel the end of the pipe with a beveling tool after the pipe is field cut. Place a clearly visible position mark at the correct distance from the end of the field-cut pipe.
 5. Solvent Weld or Butt Fusion Joints. All cutting and field fabrication shall be done according to printed recommendations of the pipe manufacturer or associated pipe manufacturer organizations. Piping shall be cleaned to the extent required for joint completion.
- C. Installation of Slipline Pipe. Not applicable.

3.05 Sewer Manhole Installation. Details A, B, C, D

- A. General. Manholes shall be furnished and installed to depths and dimensions shown on the Construction Drawings and/or staked in the field. Manholes shall be constructed of precast concrete rings in accordance with details shown on the Construction Drawings.
- B. Connections to Manholes. Connection of manhole with pipe shall be made with flexible connector detail. In addition, extra care shall be taken by grouting or other means of sealing to assure positive watertight manholes around the inlet or outlet pipes.
- C. Manhole Floor and Inverts. Manhole bases shall be constructed to conform to the details shown on the Drawings. The invert channels shall be smooth and semi-circular in shape, conforming to the inside of the incoming and outgoing sewer pipelines. Changes in direction of flow shall be made with a smooth curve of as large a radius as the size of the manhole will permit. Changes in size and grade of the channels shall be made gradually and evenly. Where large differences in invert elevations exist, sloped flow channels shall be formed so the wastewater does not undergo a vertical drop. The invert channels may be formed directly in the concrete of the manhole base. The floor of the manhole outside the channel shall be smooth and shall slope toward the channels.
- D. Finish Grade and Adjustment. To bring the manhole cover to the correct elevation, the top section of each manhole shall be constructed of pre-cast concrete grade adjustment rings. These rings shall be not less than 6 inch wide and furnished in heights to allow for 2 inch adjustments. Grade adjustment with rings shall be 8 inch maximum and 2 inch minimum. All rings shall be grouted in place with non-shrink grout.

Finish Grade and Adjustment HDPE Alternate. High-density polyethylene grade rings may also be used to bring manhole cover to correct elevation. Grade rings shall be molded from HDPE as defined in ASTM Specification D1248-84.

Available thicknesses are 1.25 inch, 1.50 inch, 2.00 inch 4.00 inch and a sloped thickness 0.75 inch x 1.50 inch. When this alternate is used, pavement slope

Roaring Fork Water & Sanitation District

should be matched using one or more sloped rings. Manufacturer's reference - Ladtech, Inc., or approved equal.

Grade rings shall be a combined maximum height of 1 foot. If more than 1 foot of grade rings are required then a 1 foot manhole section shall be installed along with grade rings.

- E. Manhole Stubs. Stubs shall extend approximately 24 inch from the outside face of the manhole and shall be capped or plugged with manufactured fittings to form a watertight installation.
- F. Manhole Steps. Manholes steps shall be installed so that the first step is a maximum of 18 inches from finished grade. The steps below the first step shall be installed within 1 inch horizontally of the first step. This will be measured by hanging a plumb bob from a corner of the top step and measuring from that line to the same corner of each step.

3.06 Connection to Existing Sewer Facilities. Connections to existing sewer facilities where live flows exist shall be made only after prior consultation with and receipt of written permission from the District Engineer. No bypass of sewage to the surface will be allowed in the completion of this connection. All connections between pipes of different materials shall be made with approved manufactured connectors.

3.07 Protection of Water Supplies. Sewer lines shall be located a minimum of 10 feet horizontally from existing or proposed water mains. Where the sewer line crosses above the waterline, or is less than 18 inches vertically below the invert of the water line, or is less than 10 feet horizontally from the water main, the sewer line shall be made impervious by either of the methods listed below or as shown in Detail 14.

- A. The sewer pipe shall be reinforced with a concrete encasement. The encasement shall be at least 6 inches thick on all sides of the sewer pipe and extend 10 feet on either side of the water main. Use three No. 4 rebar the length of the encasement.
- B. Install one piece of C-900 PVC pipe centered over the waterline with a solid sleeve coupler with transition gaskets
- C. Install a ground collar over the two sewer joints on either side of the water crossing. The grout collar shall be around the entire perimeter of the joint.

If clearance is less than 12 inches vertically, the space between the water and sewer mains shall be filled by 3,000 psi concrete.

In all cases, bedding material shall be used to prevent any settling of the higher pipe.

3.08 Service Connections. Customer service connections shall be installed in accordance with Detail F. After the service connection is installed, the end shall be plugged watertight with a manufactured plug and marked with a stake except as shown otherwise on the Drawings.

4.00 FIELD QUALITY CONTROL

4.01 Alignment and Grade. Sewer pipelines will be checked by the Engineer to determine whether any displacement of the pipe has occurred after the trench has been backfilled. The test will be as follows:

A light will be flashed between manholes, or if the manholes have not yet been constructed, between the locations of the manholes, by means of a flashlight. If the illuminated interior of the pipeline shows poor alignment, displaced pipe, earth or other debris in the pipe, or any other kind of defect, the defects as determined by the Engineer shall be remedied by the Contractor at their own expense. Test will be repeated after completion of backfilling and any poor alignment, displaced pipe, or other defects determined by the Engineer, shall be corrected.

4.02 Leakage Test. Sewerlines shall be tested using a low-pressure air test only; water tests will not be allowed. Only after the sanitary sewers, including appurtenances and sanitary laterals, water mains and water services have been installed and backfilled to finish grade, shall the Contractor proceed with an air test on the installed facilities.

- A. Low Pressure Air Test Procedure. The section of sewerline to be tested should be flushed and cleaned prior to conducting the low-pressure air test. This serves to clean out any debris, wet the pipe, and produce more consistent results. Isolate the section of sewerline to be tested by means of inflatable stoppers or other suitable test plugs. One of the plugs should have an inlet tap, or other provision for connecting a hose to a portable air control source.

If the test section is below the groundwater level, determine the height of the ground water above the spring line of the pipe at each end of the test section and compute the average. For every foot of groundwater above the pipe spring line, increase the gauge test pressure by 0.43 pounds per square inch. Connect the air hose to the inlet tap and a portable air control source. The air equipment should consist of necessary valves and pressure gauges to control the rate at which air flows into the test section and to enable monitoring of the air pressure within the test section. Also, the testing apparatus should be equipped with a pressure relief device to avoid the possibility of loading the test section with the full capacity of the compressor. Locate valves and gauges above ground.

Add air slowly to the test section until the pressure inside the pipe is raised to 5.0 psig greater than the average backpressure of any groundwater that may be over the pipe. After a pressure of 5.0 psig is obtained, regulate the air supply so that the pressure is maintained between 4.5 and 5.0 psig (above the average ground water back pressure) for a period of 2 minutes. This allows the air temperature to stabilize in equilibrium with the temperature of the pipe walls. The pressure will normally drop slightly until temperature equilibrium is obtained.

Determine the rate of air loss by the time/pressure drop method. After the 2 minute air stabilization period, the air supply is disconnected and the test pressure allowed decreasing to 4.5 psig. The time required for the test pressure to drop from 4.5 psig to 4.0 psig is determined by means of a stopwatch and this time interval is then compared to the required time in the attached table to determine if the rate of air loss is within the allowable time limit. If the time is equal to or greater than the times indicated in the tables, the pipeline shall be deemed acceptable.

Nominal Pipe Size (Inches)	Minimum Test Time (min/100 feet)
3	0.2
4	0.3
6	0.7
8	1.2
10	1.5
12	1.8
15	2.1
18	2.4
21	3.0
24	3.6
27	4.2
30	4.8
33	5.4
36	6.0

Upon completion of the test, open the bleeder valve to allow air to escape. Plugs should not be removed until all air pressure in the test section has been released. During this time, no one should be allowed in the trench or manhole while the pipe is being decompressed. Air test shall also include service lines and appurtenances.

4.03 Manhole Inspection. During the construction of the manholes, the Contractor shall, in accordance with good practice, ensure that no earth, sand, rocks or other foreign material exists on the joint surfaces during assembly of the section. The Engineer shall check each manhole to determine whether the manhole fulfills the requirements of the approved Drawings and Specifications.

- A. Visual Examination. The Engineer shall visually check each manhole, both exterior and interior, for flaws, cracks, holes, or other inadequacies that might affect the operation or watertight integrity of the manhole. Should any inadequacies be found, the Contractor, at their own expense, shall make any repairs deemed necessary by the Engineer.
- B. Leakage Test. All manholes shall be tested for leakage and all tests shall be witnessed by the Engineer. The leakage test shall be conducted after the manhole has been backfilled to finished grade and shall be carried out in the following manner:
 - 1. Stub-outs, manhole boots and pipe plugs shall be secured to prevent movement while the vacuum is drawn.
 - 2. Installation and operation of vacuum equipment and indicating devices shall be in accordance with equipment specifications for which performance information has been provided by the manufacturer and

approved by the Engineer.

3. A measured vacuum of 10 inches of mercury shall be established in the manhole. The time for the vacuum to drop to 9 inch of mercury shall be recorded.

4. Acceptance standards for leakage shall be established from the elapsed time for a negative pressure change from 10 inches to 9 inches of mercury. The maximum allowable leakage rate for a 4 foot diameter manhole shall be in accordance with the following:

MANHOLE DEPTH	MINIMUM ELAPSED TIME FOR A PRESSURE CHANGE OF 1 INCH Hg
10 ft. or less	60 seconds
> 10 ft. but < 15 ft.	75 seconds
> 15 ft. but < 25 ft.	90 seconds

For manholes 5 feet in diameter, add an additional 15 seconds and for manholes 6 feet in diameter, add an additional 30 seconds to the time requirements for 4 foot diameter manholes.

5. If the manhole fails the test, necessary repairs shall be made and the vacuum test and repairs shall be repeated until the manhole passes the test or the manhole shall be tested in accordance with the standard exfiltration test and rated accordingly.

4.04 Deflection Test for Non-Rigid Pipe. The maximum allowable pipe deflection for a completely backfilled, non-rigid sewer pipe shall not exceed 5 percent of the nominal internal pipe diameter. Deflections in non-rigid pipe shall be checked by measurement or by pulling a mandrel with the minimum allowable diameter through the pipe. The minimum allowable diameter shall be equal to the minimum interior diameter of the pipe, as specified in the applicable portions of the ASTM Standard Specifications or the pipe manufacturer's recommendations, minus 5 percent of the minimal interior diameter of the pipe. Those sections of non-rigid pipe with deflections greater than the maximum allowable 5 percent shall not be acceptable and the Contractor will remove and replace these sections at their own expense.

Deflection tests will be run if in the opinion of the Engineer testing is warranted. The program for testing shall be mutually determined by the Engineer and the Contractor. The Contractor shall furnish all labor, tools and equipment necessary to make the tests and to perform any work incidental thereto.

4.05 Pressure Testing of Force Main and Low Pressure, Small Diameter Sewerline. Make pressure and leakage tests on all newly laid pipe. Furnish all necessary equipment and material, make all taps in the pipe as required, and conduct the tests. The tests shall be conducted between valved sections of the pipeline, or as approved by the Engineer. The Engineer will monitor the tests.

Furnish the following equipment and material for the tests:

<u>Amount</u>	<u>Description</u>
2	Approved graduated containers
2	Pressure gauges
1	Hydraulic force pump approved by the Engineer
1	Additional 0.5 inch pressure tap for Engineer's test gauge
	Suitable hose and suction pipe as required

Conduct the tests after the trench has been completely backfilled. Where any section of pipe is provided with concrete reaction blocking, do not make the pressure test until at least 5 days have elapsed after the concrete thrust blocking is installed. If high-early cement is used for the concrete thrust blocking, the time may be cut to 2 days.

Conduct pressure test in the following manner, unless otherwise approved by the District Engineer: after the trench has been backfilled, fill the pipe with water, expelling all air during the filling. The test pressure shall be 1.5 times normal working pressure at the point of lowest elevation of the test gauge.

A. Duration

1. The duration of each pressure test shall be 2 hours, unless otherwise directed by the District Engineer.

B. Procedure

1. Slowly fill the pipe with water and allow to stand for 24 hours. Expel all air from the pipe. Allow and maintain the specified test pressure by continuous pumping if necessary for the entire test period. The test pressure shall be calculated for the point of lowest elevation, or as specified by the District Engineer. The pump suction shall be in a barrel or similar device, or metered so that the amount of water required to maintain the test pressure may be measured accurately.
2. Before the line is pressurized, the Engineer shall verify that all necessary main line valves are open or closed with regard to the section of line being tested.

C. Leakage

1. Leakage shall be defined as the quantity of water necessary to hold the specified test pressure for the duration of the test period. No pipe installation will be accepted if the leakage is greater than the number of gallons per hour as determined by the following formula:

$$L = \frac{SD\sqrt{P}}{148,000}$$

In the above formula:

L = Allowable leakage, in gallons per hour.

S = The length of pipe being tested, in feet.

D = Nominal diameter of pipe, in inches.

P = Average test pressure during the leakage test, in pounds per square inch gauge.

D. Correction of Excessive Leakage

1. Should any test of pipe laid, reveal leakage greater than that allowed, locate and repair the defective joints or pipe until the leakage of a subsequent test is within the specified allowance.

4.06 Televising Main. All sewer connection lines 8 inches or larger shall be televised. The video shall have a running footage meter showing the exact footage from the entry manhole. The electronic copy shall be provided with a log showing the location of all defects and service lines.

Installed sewerline shall be re-televised at the end of the warranty period to verify that no movement has occurred.

5.00 DESIGN CRITERIA - GRAVITY SEWER

5.01 Sizing. All collection sewer lines shall be designed to flow approximately half full at peak flow. One hundred gallons per capita day shall be used as the per capita contribution for average daily flow. A peaking factor of 4.0 shall be used for peak flow. Minimum line size shall be 8 inches.

5.02 Velocities. All velocities shall be maintained between 2.5 fps and 15 fps. Minimum velocity shall be 2 fps.

5.03 Slope. Minimum sewer line slopes shall be as follows:

8"	0.004 ft/ft
10"	0.003 ft/ft
12"	0.0022 ft/ft
15"	0.0015 ft/ft
18"	0.0012 ft/ft
21"	0.0010 ft/ft
24"	0.0009 ft/ft
27"	0.0008 ft/ft

5.04 Distances. The distance between manholes shall not exceed 400 feet, unless approved by the District Engineer. Manholes shall be required on all changes in grade or alignment.

5.05 Curved Sewer. Not Allowed.

5.06 Small Diameter Pressure Sewerlines. Under special conditions, such as low tributary population, or areas where it may be determined by the District, that central lift stations are not

Roaring Fork Water & Sanitation District

applicable, small diameter pressure sewer technology may be used. Small diameter technology may include pressure, vacuum and small diameter, gravity sewers.

The Engineer shall submit an integrated plan for review and approval. That plan shall include the design of main line sewers and their appurtenances, service lines and on-site pumping systems. Components of the integrated design shall include, but not be limited to, the following:

- A. The District will maintain a list of acceptable manufacturers for these integrated systems. Those manufacturers' lists may be obtained from the District office.
- B. The on-site pumping system shall include a simplex or duplex, effluent or grinder pump, alarm and monitoring controls, an effluent pipe check valve, a means to isolate the on-site pumping systems during maintenance and a minimum 20 foot usable access easement to allow inspection by District personnel.
- C. The service line shall include a shutoff means to allow extension of the service line onto individual properties after the main system is in operation.
- D. The main line sewer system shall include air and vacuum release valves with vaults at high points, pressure cleanouts at high points (in combination with air release and vacuum valve vault), pressure cleanouts at intersections and pressure cleanouts at minimum 1,000 foot intervals. Pressure cleanouts shall be installed in a standard manhole for access.
- E. The system design shall provide for minimum cleansing velocities of 2 fps at design conditions. Minimum cleansing velocities shall be maintained at less than design flow conditions where excessive headloss at design flows are not introduced. It is recognized that minimum cleansing flows may not be maintained during the early stages of build-out. A plan shall be prepared to address operations during the times when cleansing velocities cannot be maintained. This plan should investigate multiple main lines, odor control facilities and increased maintenance requirements.

6.00 GREASE INTERCEPTORS

6.01 General. Because of the impact of grease on the District's lines and treatment plant, grease interceptors are required on establishments preparing or serving food.

All grease interceptors shall be new and the interceptor and its installation shall be in conformance with the latest edition of the Uniform Plumbing Code except as modified herein.

6.02 Requirements For Grease Interceptors. An approved type grease interceptor complying with the provisions of this section shall be installed in the waste line leading from sinks, drains and other fixtures or equipment in the following establishments: Restaurants, cafes, lunch counters, cafeterias, bars and clubs; hotels, hospitals, factory or school kitchens, or other establishments where grease may be introduced into the drainage or sewage system. A grease interceptor is not required for individual dwelling units or for any private living quarters.

6.03 Specifications and Procedures For Grease Interceptors.

- A. Plans shall be submitted to and approval obtained from the District prior to the installation of any grease interceptor in any establishment set forth in Subsection 6.02.

- B. No grease interceptor shall be installed which has an approved rate of flow of more than 55 gallons per minute, except when specially approved by the District.
- C. No grease interceptor shall be installed which has an approved rate of flow of less than 20 gallons per minute.
- D. Each plumbing fixture or piece of equipment connected to a grease interceptor shall be provided with an approved type flow control or restricting device installed in a readily accessible and visible location in the tail piece or drain outlet of each such fixture. Flow control devices shall be so designed that the total flow through such device or devices shall at no time be greater than the rated capacity of the interceptor. No flow control device having adjustable or removable parts shall be approved.
- E. Each grease interceptor required by this section shall have an approved rate of flow which is not less than that given in the District's EQR schedule for the total number and size of fixtures connected thereto or discharging thereunto. The total capacity in gallons from fixtures discharging into any interceptor shall not exceed 2.5 times the flow rate of the subject interceptor.

Any grease interceptor installed or located in such a manner that the inlet is more than 4 feet lower in elevation than the outlet of any fixture discharging into such interceptor, shall have an approved rate of flow which is not less than 50 percent greater than that given in the District's EQR schedule.

- F. No more than 4 separate fixtures shall be connected to or discharged into any 1 grease interceptor.
- G. For the purpose of this section, the term "fixture" shall mean and include each plumbing fixture, appliance, apparatus or other equipment required to be connected to or discharged into a grease interceptor by any provision of this section.
- H. Each grease interceptor shall be vented as required by the Uniform Plumbing Code and each fixture discharging into a grease interceptor shall be individually trapped and vented in an approved manner, except that an approved type grease interceptor may be used as a fixture trap for a single fixture when the horizontal distance between the fixture outlet and the grease interceptor does not exceed 4 feet and the vertical tail pipe or drain does not exceed 2 feet.
- I. Each grease interceptor shall be installed and connected so that it shall be at all times easily accessible for inspection, cleaning and removal of the intercepted grease.
- J. Interceptors shall be maintained in efficient operating conditions by periodic removal of the accumulated grease. No such collected grease shall be introduced into any drainage piping, public or private sewer, and it shall be disposed of in an environmentally safe manner. Maintenance and inspection shall occur every 6 months or as approved by the District and the records shall be provided to the District once a year.

- K. Each grease interceptor shall be constructed of durable material satisfactory to the District and shall have a full size, gas tight cover that can be easily and readily removed.
- L. No water-jacketed grease interceptor shall be approved or installed.
- M. Each grease interceptor shall have an approved water seal of not less than 2 inches in depth or the diameter of its outlet, whichever is greater.
- N. No grease interceptor required by this section shall be installed until the type and model of each size thereof has been approved by the District.
- O. The District may require such tests as may be necessary to determine the grease collecting efficiency of the various types and kinds of grease interceptors to establish the rate of flow or other rating thereof. Such test requirements may be revised or modified from time to time as may be deemed necessary by the District. A list of approved and acceptable interceptors shall be kept on file in the office of the District.
- P. No grease interceptor shall be installed which does not comply in all respects with a type or model of each size approved and accepted by the District. Whenever it shall come to the attention of the District that any grease interceptor does not so comply, the District shall immediately suspend or revoke such approval.

7.00 CLEANOUTS

All service lines shall have a minimum of 1 cleanout, and then 1 cleanout per 100 feet of pipeline length. A cleanout consisting of a wye the diameter of the service line shall be provided at the property line between the building being served and the main line. The upper 24 inch of the vertical riser shall be cast or ductile iron and at grade in unimproved areas, finished driveways, sidewalks, etc., and be plugged with a water-tight cast iron plug (see Details G and H).

End of Section XI

XII. TRENCHING, BACKFILLING AND COMPACTION

1.00 GENERAL

1.01 Scope. Work to be performed under this section shall include all labor, equipment, materials and miscellaneous items necessary to perform all excavation, backfilling and compaction of underground pipelines, conduits, cables and appurtenances shown on the Drawings and specified herein.

All work within the rights-of-way of the Federal Government of the Colorado Division of Highways, County Governments or Municipal Governments shall be done in compliance with requirements issued by those agencies. All such requirements shall take precedence over these Specifications. It shall be the Contractor's responsibility to secure all required excavation permits and pay all costs thereof. Contractor will be required to obtain necessary road cut permits.

1.02 Field Conditions.

- A. Existing Utilities. Underground utilities, except service lines, known to the Engineer have been shown on the Drawings. Locations are approximate only and may prove to be inaccurate. The Contractor is responsible for verification of the existence, location and protection of all utilities within the construction area.

Before commencing with work, the Contractor shall notify all public and private companies who may have utilities within the project limits. The Contractor shall coordinate with these entities all excavation performed. The Contractor shall obtain all permits required by utility owners.

In the event of damage to any existing utility, the Contractor shall be solely responsible for the repair and payment for repair of all such damage.

The Contractor shall make arrangements for and pay all costs for relocation of utilities requiring relocation as indicated on the Drawings. Should utility obstructions, not shown on the Drawings, be encountered and require relocation, the Contractor shall notify the Owner and the Engineer and shall make arrangements necessary for such relocation. The Owner shall pay the costs for such relocation.

- B. Existing Improvements. The Contractor shall restore or protect from damage all existing improvements encountered in performance of the work. Improvements damaged, as a result of this work shall be restored to original condition or better, as determined by the Engineer.

Adjacent property shall be protected by the Contractor from any damage. The Contractor shall be held solely liable for any damage to adjacent property and shall be responsible for all costs resulting from repair of such damage.

- C. Soil Conditions. It shall be the responsibility of the Contractor to examine soil conditions and characteristics, including the presence of groundwater that will be encountered within the limits of construction.

1.03 Protection of Work.

- A. Safety. All excavation shall be protected by barricades, lights, signs, etc., as required by governing federal, state and local safety codes and regulations.
- B. Sheeting, Shoring and Bracing. Where trench walls are not excavated at a stable slope, the Contractor shall provide and maintain support sufficient to prevent caving, sliding or failure and property or bodily damage. Any damage due to inadequate support shall be repaired at the sole expense of the Contractor.

Under normal construction conditions, support shall be removed as work progresses. Support shall remain installed if directed by the Engineer or if pipe does not have sufficient strength to support backfill based on trench width as defined by the sheeting. Sheeting shall not be removed after the start of backfilling.

Use of a movable trench shield or coffin box will not be allowed where pipe strength is insufficient to support backfill as defined by the trench width after the trench shield is removed.

The Contractor shall be held solely responsible for any violation of applicable safety standards. Particular attention is called to minimum requirements of OSHA and Colorado Occupational Safety and Health (COSH).

- C. Site Drainage. Excavation to be protected from surface water at all times. At no time shall excavated area be allowed to fill with storm water runoff. Contractor shall provide proper, temporary drainage structures at their cost to detour runoff from excavated areas.

1.04 Blasting. No blasting shall be permitted without written consent of the Engineer. Blasting shall be done only after Engineer receives permission from the appropriate governmental authority(ies). Blasting shall be performed only by properly licensed, experienced individuals and in a manner such that no damage to any property or persons will occur due to either the blast or debris. Contractor shall provide proof of insurance as required by these Specifications, the governing authority or as required by Engineer prior to any blasting. All damage, as the result of blasting shall be repaired, at the Contractor's expense, to the satisfaction of the Engineer. All earth or rock loosened by blasting shall be removed from excavations prior to proposed construction.

1.05 Construction in Streets. When construction operations are located within streets make provisions at cross streets and walks for free passage of vehicles and pedestrians. Do not block streets or walks without prior approval.

1.06 Submittals.

- A. Bedding Material
 - 1. Submit sieve analysis
- B. Select Fill
 - 1. Submit sieve analysis

2.00 MATERIALS

2.01 Embedment Material. Pipeline embedment material shall comply with the appropriate classes as listed below and as illustrated in the approved Construction Drawings:

- A. Class A - Use for all PVC, DIP, CMP and concrete pipe under normal construction conditions.
 - 1. Characteristics - Densely compacted Class 6 aggregate granular foundation of depth shown on Typical Details with densely compacted Class 6 aggregate 12 inches above top of pipe.
- B. Class B - Use where improper trenching or unexpected trench conditions require its use as determined by the Engineer.
 - 1. Characteristics - Concrete cradle foundation with densely compacted Class 6 aggregate base backfill to 12 inches above top of pipe, or densely compacted Class 6 aggregate granular foundation with concrete arch cover to 6 inches above top of pipe.

* 3/4 inch screened rock shall not be used unless approved by the District Engineer.

2.02 Select Material. Subject to approval by the Engineer, select material shall be allowed in place of the aggregate backfill for Class A when excavation and soil conditions allow, but only if approved by Engineer.

Contractors shall bid project based upon Class A. If Class B or select material is used, price adjustments shall be made.

- A. Characteristics - Soil materials free from rocks, clods, and organic material.

2.03 Concrete for Embedment. Shall be 2,000 psi concrete (28- day compressive strength).

2.04 Backfill Material.

- A. Characteristics - Native materials free from debris, organic matter and frozen material. Uniformly graded sufficient to allow proper compaction.
- B. Gradation - No boulders greater than 6 inch diameter in top 12 inches of backfill. Generally, no boulders greater than 12 inch diameter in remainder of trench.

3.00 METHODS AND PROCEDURES

3.01 Site Preparation.

- A. Clearing. Remove all vegetation, stumps, roots, organic matter, debris and other miscellaneous structures and materials from project site. Dispose of off site.
- B. Topsoil Removal. Strip existing topsoil from all areas to be disturbed by construction. Topsoil to be stockpiled separately from excavated materials.

3.02 Trench Excavation.

- A. Limits of Excavation. Trenches to be excavated along lines and grades shown on the Drawings, or as modified in the field by the Engineer. Trench widths for pipe loading to be measured 12 inches above top of pipe.

Minimum trench width to be the outside diameter of the pipe or conduit plus 16 inches.

Maximum trench width to be the outside diameter of the pipe or conduit plus 24 inches for all pipes or conduits with outside diameter of 24 inches or less, and plus 30 inches for all pipes or conduits with outside diameters greater than 24 inches.

If maximum trench width is exceeded, Contractor will provide at their expense, higher strength pipe or special bedding including concrete at the direction of the Engineer.

Trench excavation not to be completed more than 100 feet in advance of pipe installation. Backfill to be completed within 100 feet of pipe installation.

- B. Groundwater Control. Contractor to maintain facilities on-site to remove all groundwater from trench and keep water at least 12 inches below the trench bottom, to a point such that a firm base for pipe or conduit installation exists.
- C. Facilities shall be maintained until all concrete is cured and backfilling is in place at least 24 inches above anticipated water levels before water removal is discontinued; all water removal shall be subject to approval by the Engineer.
- D. Stockpile Excavated Material. Excavated material to be stockpiled so as not to endanger the work or public safety. Maintain existing vehicular and pedestrian traffic with minimum disruption. Maintain emergency access and access to existing fire hydrants and water valves. Maintain natural drainage courses and street gutters.

Backfill material to be segregated from stockpiled topsoil and unusable backfill materials.

- E. Excavation for Appurtenances. Excavation to be done in accordance with these Specifications and as shown on the approved Drawings. Adequate working clearances to be maintained around appurtenances. Provisions for base and

bottom preparations shall apply to all appurtenances.

Precautions to be taken to maintain trench widths in the vicinity of adjacent pipelines and conduits.

3.03 Bottom Preparation.

- A. Undisturbed Foundation. Where soils are suitable and have adequate strength, bottom to be graded and hand-shaped such that pipe barrel rests uniformly on undisturbed soil. All rocks or stones that may result in a point bearing on the pipe shall be removed.

Undisturbed grades shall be within 0.1 feet tolerance. Soils for final pipe grade placed within these limits shall be fine granular (100% passing No. 4 sieve) or may be native materials, hand compacted to 95% maximum density.

- B. Bell Holes. Material to be removed to allow installation of all fitting and joint projections without affecting placement of pipe.
- C. Over excavation. Whenever trench is over-excavated to eliminate point bearing by rocks or stones or when undisturbed grade tolerances of 0.1 foot are exceeded, the Contractor is to re-establish grade using Class 6 aggregate bedding material. Compaction shall be 95% maximum density. All work to re-establish grade shall be at the Contractor's expense.
- D. Unstable Materials. Materials that are not capable of supporting super-imposed loadings are defined as unstable materials. Should unstable materials be encountered during excavation, immediately notify Engineer. If, in the opinion of the Engineer, unstable soil excavation is required and the Contractor could not have reasonably been expected to discover the existence of such materials during their site investigation, then a contract price for Unstable Soil Excavation shall be negotiated between Owner and Contractor. No payment shall be made for materials excavated prior to notification of the Engineer and negotiation of payment for extra work.

Inclusion of a bid item for Unstable Soil Excavation indicates such excavation is anticipated. The Contractor is to notify the Engineer prior to any unstable soil excavation; no payment shall be made for excavation prior to authorization of Engineer.

- E. Rock Excavation. Rock excavation shall be defined as removal of boulders in excess of 3 cubic yards of solid or fractured rock, which makes hand shaping of the bottom impossible and which requires techniques, such as blasting or jacking for removal, other than those which are being employed by the Contractor or are normally used in trench excavation, such as use of backhoes, trenchers, draglines, etc. Should unanticipated rock conditions be encountered, immediately notify the Engineer. If in the opinion of the Engineer, rock excavation is required and the Contractor has in fact made a diligent and determined effort to remove the material using normal excavation procedures as stated above, and the Contractor could not have reasonably been expected to determine the existence of such material during their site investigation, then a contract price for rock excavation shall be negotiated between the Contractor and the Owner. No

payment shall be made for excavation performed prior to determination of a negotiated price.

Rock shall be removed to a 4 inch depth below grade. Additionally, all rock loosened during jacking, blasting, etc., shall be removed from the trench. For payment purposes, maximum trench width to be paid for shall be as defined in Subsection 3.02, A. Maximum depth to be paid for shall be 12 inch below required grade. All over-excavation shall be replaced as specified in Subsection 3.03, C.

Inclusion of a bid item for rock excavation indicates such excavation is anticipated. Contractor to notify Engineer prior to any rock excavating; no payment shall be made for excavation prior to notification.

3.04 Backfilling.

- A. Tamping Equipment. Except immediately next to the pipe, mechanical or air operated tamping equipment to be used. Hand equipment, such as T-bar to be used to pipe if necessary. Care to be taken when compacting under, along side and immediately above pipe to prevent crushing, fracturing shifting of the pipe. The Contractor is to note densities required for materials are or being backfilled and shall use appropriate approved equipment to obtain those densities.

Wheel rolling is not considered to be an adequate compaction technique to meet these Specifications and will not be allowed. Where 85% compaction is required, wheel rolling may be considered. Before acceptance, the Contractor shall backfill a portion of the trench and pay for density testing to verify adequacy of the proposed backfill techniques.

A hydro hammer may be allowed to obtain the specified density up to 4 feet in depth. The Contractor will be required to re-excavate those areas that have been tamped so that density tests can be taken to insure that the specified density is being obtained full depth.

- B. Moisture Control. Generally maintain moisture of backfill material with 2% of optimum moisture content as determined by ASTM D698. Maintain closer tolerances as needed to obtain densities required.
- C. Compaction. Maximum density (100%) based on ASTM D698 or AASHTO T99.
1. Bedding Material, including material used for over-excavation of any kind: 95%.
 2. Select Material: 95%
 3. Backfill beneath existing or proposed pavement, roadways, sidewalks, curbs, utility lines and other improvements or within 5 feet horizontally of such improvements: 95%.
 4. Backfill within public or designated right-of-way: 90% or as shown on the approved Drawings.

5. Backfill within undeveloped, green or undesignated area: 85%.
 6. Backfill for any fill over overcut grading in areas of lot/home construction: 95%.
- D. Placing Backfill. The maximum loose lifts of backfill material to be as follows: use smaller lifts where necessary to obtain required densities:
1. Bedding and select material: 6 inches (or see Section 3.03A).
 2. Backfill Material: 12 inches where 95% compaction required; 24 inch where less than 95% compaction required.
- E. Backfilling Appurtenances. Backfilling to be done generally at the same time as adjacent pipelines. Backfilling procedure to conform to this section. Use special techniques or materials as shown on drawings.
- F. Disposal of Excess Excavation. Contractor to dispose of excess excavation off site. The Owner shall have the right to elect to have the excess excavation disposed of at a designated site within the project limits. Excavation may be wasted on-site only if approved by the Engineer. Disposal in any case shall be the sole responsibility of the Contractor.
- G. Jetting. Jetting and water inundation are generally not permitted methods of compaction. The Engineer may allow jetting under certain field conditions. Techniques including depth of lifts, amount of water to be used, penetration of hose jet, etc., shall be at the direction of the Engineer. No jetting will be allowed on materials with a 200 minus gradation of greater than 15%. Contractor shall pay cost of all water used, soil classification testing and retesting or recompaction required. No jetting shall be done prior to written approval and direction of the Engineer.
- H. Maintenance of Backfill. Contractor to maintain all backfill in a satisfactory condition during the extent of the contract and warranty period. All surface deterioration determined to be the responsibility of the Contractor and the Contractor upon notice by the Owner shall repair all settlement at once. All costs for repair and all liability, as a result of surface deterioration or settlement, shall be the responsibility of the Contractor.
- I. Clay Barrier Water Stops. Because of the presence of ground water, a clay barrier may be required to be installed full depth in trench in place of all bedding material and backfill. This barrier shall be full depth and two feet thick and installed every 100 linear feet of trench. Clay barrier installation shall be considered incidental to the pipe installation and not paid for separately.

3.05 Surface Restoration. All existing surface improvements and site conditions disturbed or damaged during construction to be restored to a condition equal to pre-construction condition. All restoration costs are considered incidental to excavation and backfill.

- A. Improvements. Replace, repair or reconstruct all improvements as required. Work will not be accepted until restoration is accepted by Engineer and all affected property owners. Improvements include, by example, other utilities, culverts, structures, curb and gutter, mailboxes, signs, sprinkler systems, etc.
- B. Final Grading. The Contractor is to re-establish existing final grade or finish final grades as modified and shown on the approved Drawings. The Contractor is to backfill to proper subgrade elevation with backfill material to allow placement of surface improvements or materials.
- C. Roadways. All roadways to be restored to original condition with material types removed. Materials and methods to conform to applicable portions of current Colorado Department of Transportation (CDOT) specifications. Additional requirements are:
 - 1. Minimum base course material on gravel roadways or minimum depth gravel on hard surface roadways to be 8 inch, unless shown otherwise on approved Drawings.
 - 2. Minimum bituminous surfacing to be 3 inch unless shown otherwise on approved Drawings.
 - 3. Minimum concrete pavement surfacing to be 6 inch, unless shown otherwise on approved Drawings.

4.00 QUALITY CONTROL - FIELD

4.01 Compaction. It should be fully understood that it will be the sole responsibility of the Contractor to achieve the specified densities for all embedment and backfill material placed. Contractor will be responsible for ensuring that correct methods are being used for the placement and compaction of said materials. Correct backfill methods include, but are not limited to:

- A. Use of proper equipment for existing soil condition encountered.
- B. Moisture content of existing soils; determination if water should be added or if soil should be air dried to reduce moisture content.
- C. Thickness of backfill lift. Contractor may, at their own expense, have an approved geotechnical engineer monitor the methods of backfill and compaction used to ensure that the desired densities are being obtained. Inspection and testing will be performed as directed by the District. Testing will be conducted as a quality control check to verify the Contractor's compliance with the standards indicated the Specifications.

4.02 Inspection and Testing. Inspection and testing to be performed at the direction of the Engineer. Contractor to cooperate fully with all persons engaged in testing. Contractor to excavate as required to allow testing. Contractor to backfill all test excavations in accordance with these Specifications. Any areas, which require a specified density, including fill, backfill, trenches, embankments, road base, hot bituminous pavement, backfill for structures, shall be tested.

4.03 Density Testing and Control.

- A. Reference Standards. Density/moisture relationships to be developed for all soil types encountered according to ASTM D698 or AASHTO T99.
- B. Field Testing. Testing for density during compaction operations to be done in accordance with ASTM D2922 using nuclear density methods.
- C. Frequency of Testing. Minimum of 1 test every 250' trench per lift or as directed by Engineer. Contractor to excavate to depths required by District for testing and backfill test holes to density specified.
- D. Retesting. In the event of failure to meet compaction criteria, Contractor shall re-excavate and re-backfill at direction of District. All retesting to be paid for by Contractor and to be performed by soils testing firm approved by the District.

End of Section XII

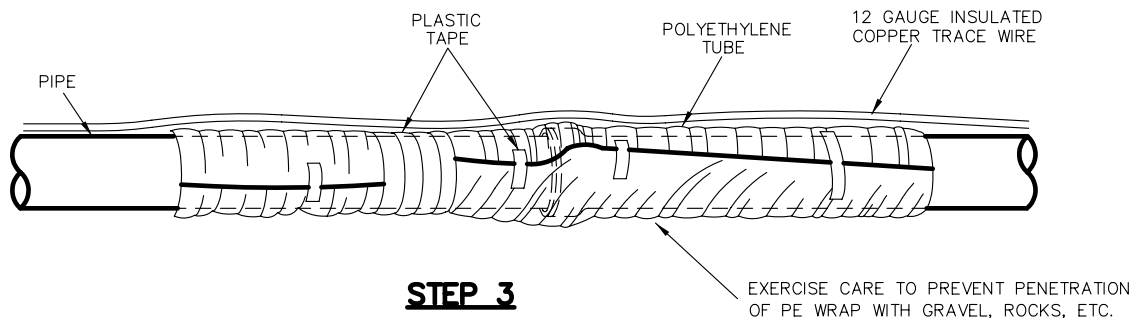
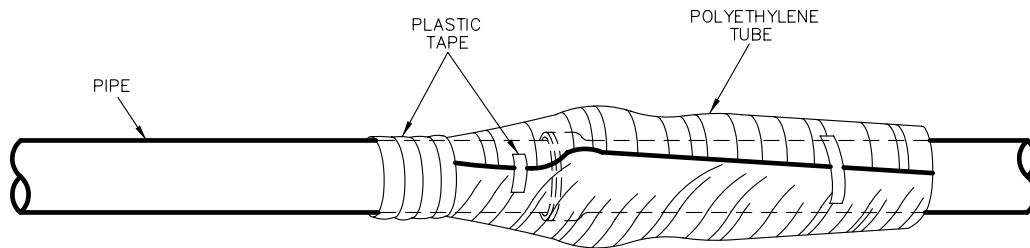
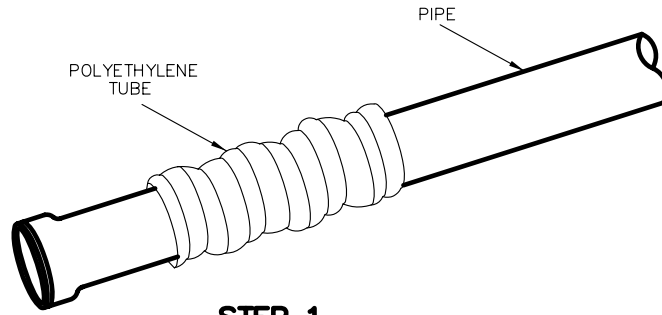

FIELD INSTALLATION – POLYETHYLENE WRAP

WHERE SPECIFICALLY REQUIRED FOR SOIL APPLICATIONS

STEP 1 – PLACE TUBE OF POLYETHYLENE MATERIAL ON PIPE PRIOR TO LOWERING IT INTO PLACE

STEP 2 – PULL THE TUBE OVER THE LENGTH OF THE PIPE. TAPE TUBE TO PIPE AT JOINT. FOLD MATERIAL AROUND THE ADJACENT SPIGOT END AND WRAP WITH TAPE TO HOLD THE PLASTIC TUBE IN PLACE.

STEP 3 – OVERLAP FIRST TUBE WITH ADJACENT TUBE AND SECURE WITH PLASTIC ADHESIVE TAPE. THE POLYETHYLENE TUBE MATERIAL COVERING THE PIPE SHALL BE LOOSE. EXCESS MATERIAL SHALL BE NEATLY DRAWN UP AROUND THE PIPE BARREL, FOLDED ON TOP OF PIPE AND TAPED IN PLACE.

POLYETHYLENE WRAP

DETAIL "1"

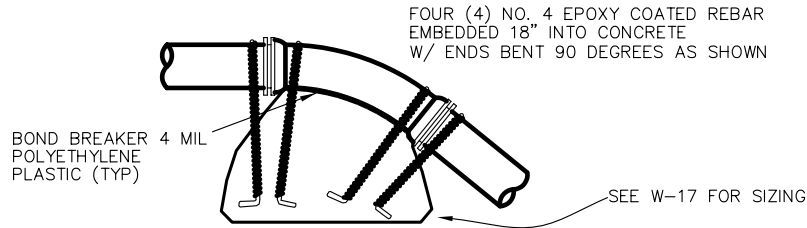

VERTICAL THRUST BLOCK - SECTION

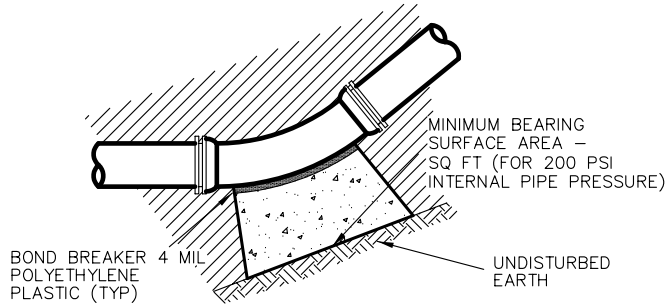

BENDS - PLAN

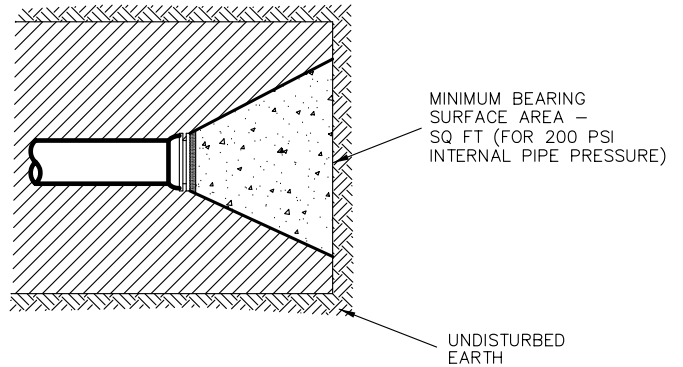

DEAD END - PLAN

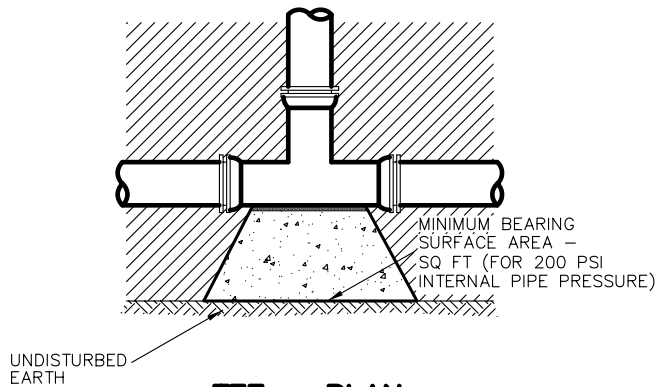

TEE - PLAN

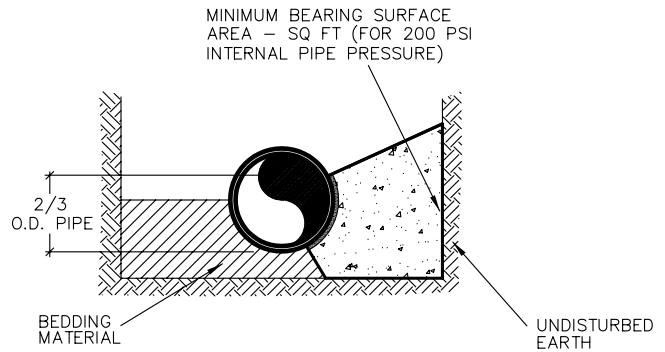

TYPICAL CROSS SECTION

MINIMUM BEARING SURFACE (SF)
FOR 200 PSI AND LESS

SIZE OF PIPE	BENDS				TEE OR DEAD END
	11-1/4°	22-1/2°	45°	90°	
6"	1.3	2.5	5.0	9.0	6.4
8"	1.3	2.5	5.0	9.0	6.4
10"	1.9	3.8	7.4	13.7	9.7
12"	2.7	5.4	10.5	19.3	13.7
16"	4.7	9.3	9.1	33.6	23.8
20"	7.2	14.3	28.0	51.8	36.6

MINIMUM BEARING SURFACE (SF)
FOR 250 PSI AND LESS

SIZE OF PIPE	BENDS				TEE OR DEAD END
	11-1/4°	22-1/2°	45°	90°	
6"	1.6	3.1	6.2	11.4	8.0
8"	1.6	3.1	6.2	11.4	8.0
10"	2.4	4.7	9.25	17.1	12.0
12"	3.4	6.7	13.1	24.2	17.1
16"	5.8	11.6	22.7	42.0	29.7
20"	9.0	17.9	35.0	64.8	45.8

NOTES:

- FOR 200 PSI INTERNAL PRESSURE, INCLUDING WATER HAMMER
- MEGALUG RESTRAINTS MAY BE USED IN CONJUNCTION WITH THRUST BLOCKS WITH PRIOR APPROVAL FROM THE DISTRICT
- MINIMUM AREA REQUIRED WILL BE THAT OF AN 8-INCH MAIN
- ALL THRUST BLOCKS SHALL BE FORMED. THE MINIMUM THICKNESS FORM MATERIAL SHALL BE 3/8" PLYWOOD
- BEARING AREA BASED ON SOIL BEARING PRESSURE OF 2000 lb/sf
- CONCRETE SHALL HAVE A 28 DAY COMPRESSION STRENGTH OF 3000 psi

CONCRETE THRUST BLOCKS

DETAIL "2"

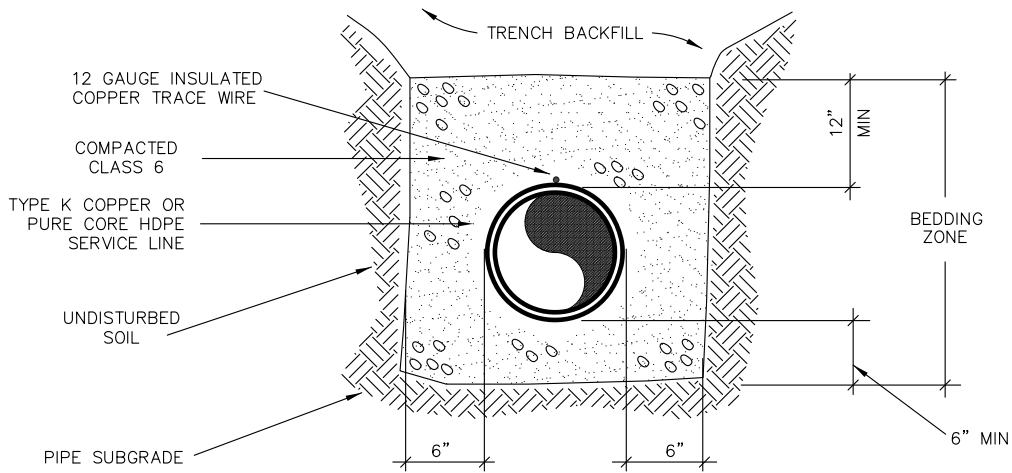

SERVICE STUB-OUT BEDDING

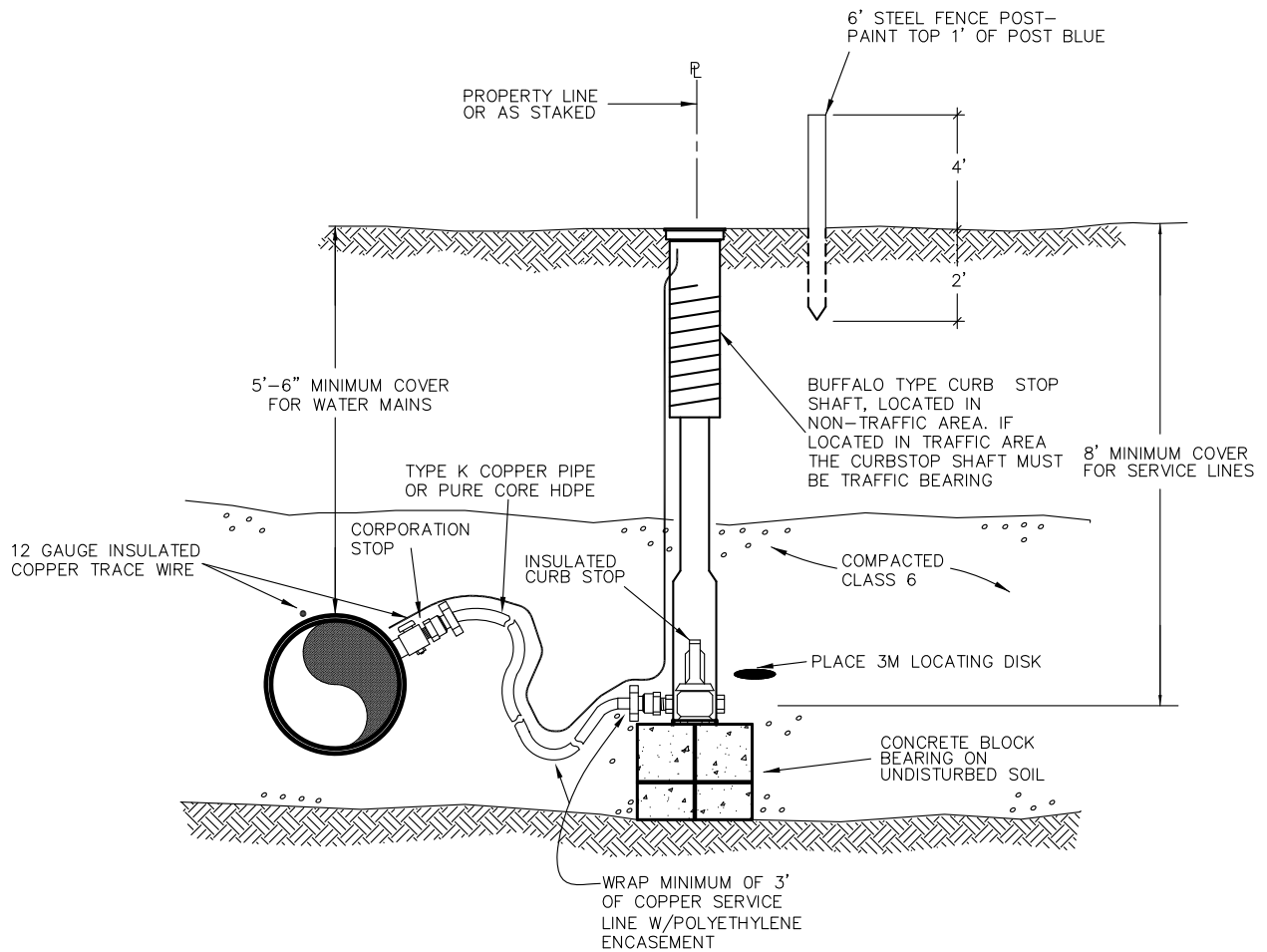

ELEVATION

GENERAL NOTES

1. CURB STOP TO BE LOCATED AT THE PROPERTY LINE OR AT THE EDGE OF EASEMENT-WHICHEVER IS CLOSER TO THE MAIN.
2. CURBSTOP - ALL FITTINGS SHALL BE COMPRESSION FITTINGS.
3. CURBSTOP - MANUFACTURER REFERENCE MUELLER B25204 OR APPROVED EQUAL.

WATER SERVICE STUB OUT

DETAIL "3"

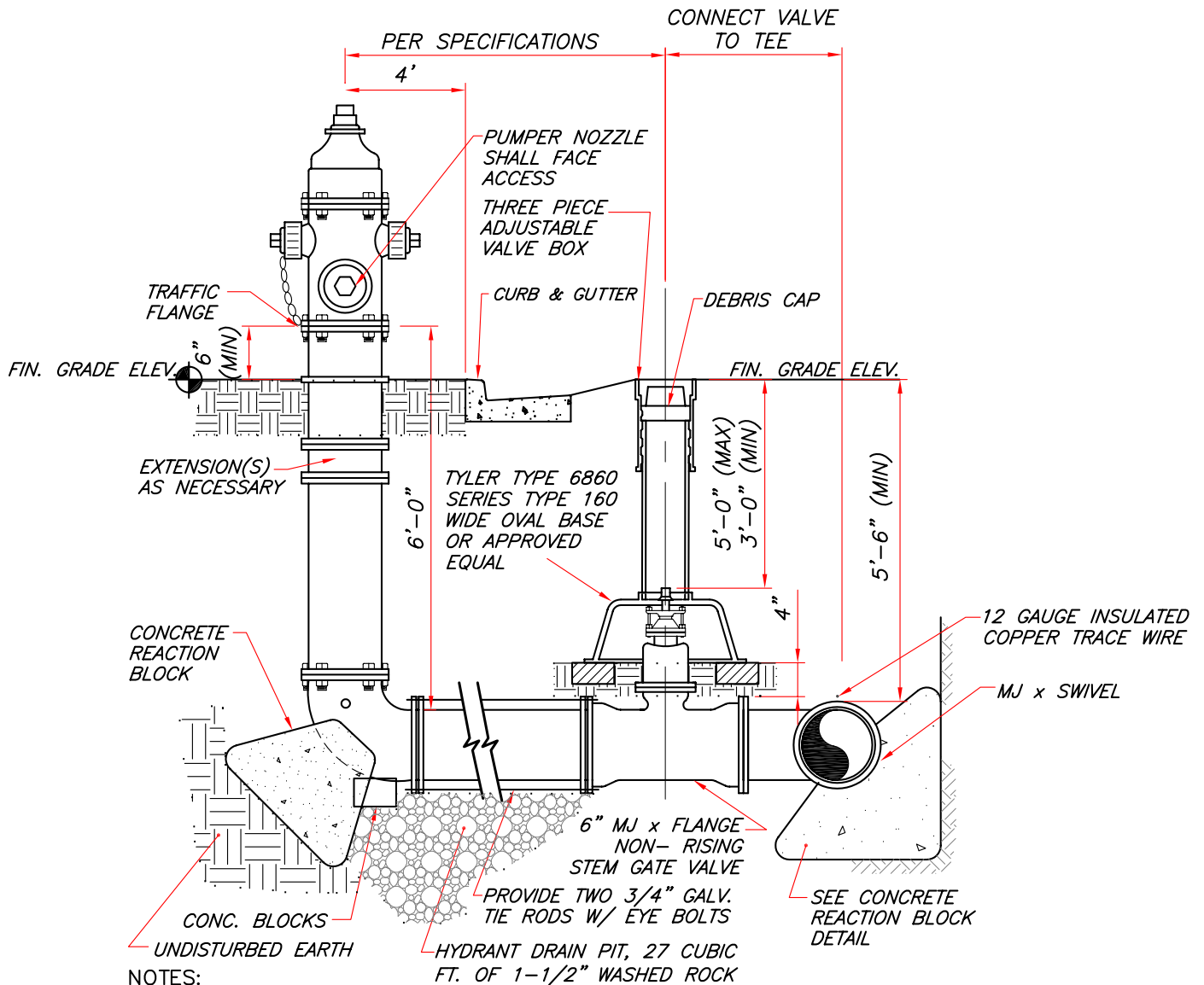

NOTES:

- 1) ALL JOINTS FROM MAIN TO HYDRANT SHALL BE RESTRAINED MECHANICAL JOINTS OR FLANGED JOINTS.
- 2) HYDRANT, VALVE AND FITTINGS TO BE 250 P.S.I. RATED.
- 3) POLYETHYLENE WRAP SHALL COVER D.I.P. ASSEMBLY FROM HYDRANT BASE TO WATER MAIN.
- 4) ALL HYDRANT LEAD PIPING TO BE 6" CLASS 250 D.I.P. UNLESS OTHERWISE NOTED
- 5) CENTERLINE OF HYDRANT TO BE 4'-0" FROM BACK OF CURB UNLESS OTHERWISE NOTED.
- 6) INSTALL VALVE STEM EXTENSION AS NEEDED TO INSURE THE DISTANCE FROM VALVE BOX LID TO TOP OF NUT SHALL NOT EXCEED 5'-0"

**FIRE HYDRANT ASSEMBLY
INSTALLATION DETAIL**

DETAIL "4"

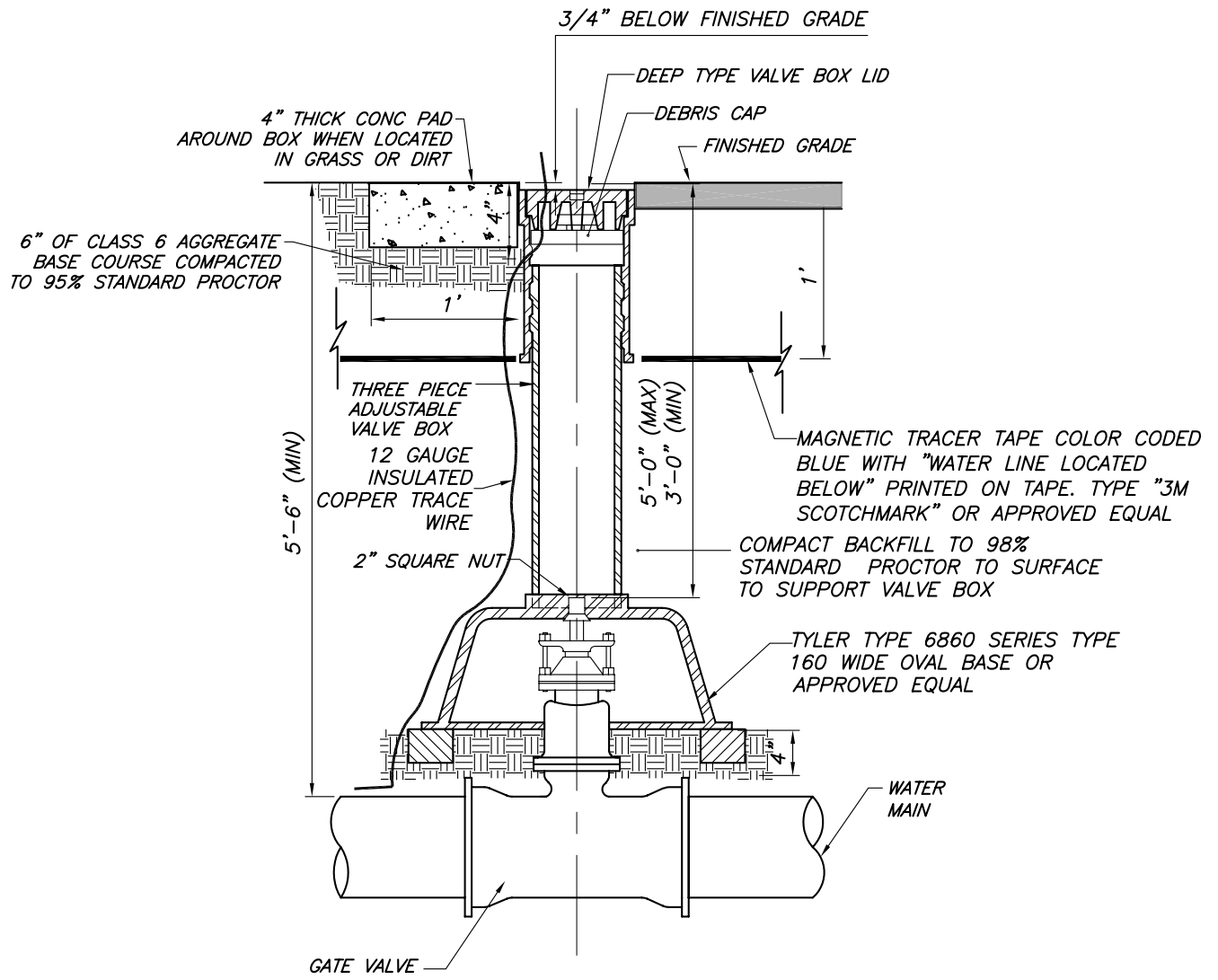

TYPICAL GATE VALVE

NOTES:

1. ALL VALVES ADJACENT TO FITTING SHALL BE MJ. IN LINE VALVES TO BE MJ x MJ. DESIGN LOCATIONS OF VALVES ARE OUTSIDE OF CONCRETE, CURB/GUTTER AND VALLEY PANS.
2. INSTALLED VALVES WHICH CONFLICT WITH CONCRETE AREAS SHALL BE RELOCATED AT THE CONTRACTOR'S EXPENSE.
3. THIS DETAIL DOES NOT APPLY TO HYDRANT ASSEMBLY VALVES.
4. INSTALL VALVE STEM EXTENSION AS NEEDED TO INSURE THE DISTANCE FROM VALVE BOX LID TO TOP OF NUT SHALL NOT EXCEED 5'-0"
5. THE TRACER WIRE SHALL BE EXTENDED TO THE SURFACE AT ALL VALVES AND FIRE HYDRANTS. THE WIRE SHALL BE EXTENDED TOWARDS THE GROUND ON THE OUTSIDE OF THE VALVE BOX UNTIL THE WIRE IS WITHIN FOUR INCHES (4") OF THE TOP OF THE LID, AT WHICH POINT IT SHALL BE BROUGHT BACK INSIDE THE BOX AND SECURELY FASTENED. SUFFICIENT SLACK IN THE OUTSIDE OF THE WIRE SHALL BE PROVIDED TO COMPENSATE FOR ANY FUTURE ADJUSTMENT TO THE VALVE BOX.

DETAIL "5"

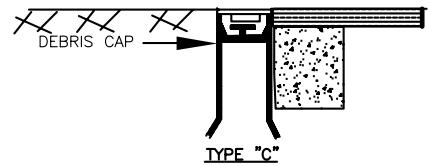
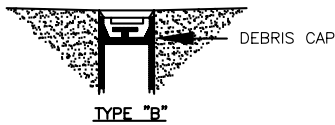
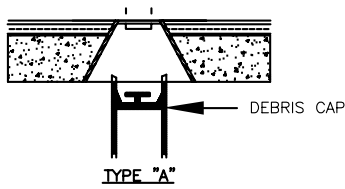

NOTES

1. DEBRIS CAP SHALL BE INSTALLED AS CLOSE UNDER THE CAST IRON COVER WITHOUT INTERFERING WITH COVER OPERATION.
2. FLEXIBLE SKIRT SHALL BE TRIMMED TO PROVIDE A SMOOTH CONTACT WITH THE INTERIOR DIAMETER OF THE PIPE.
3. THE DEBRIS CAP SHALL BE MANUFACTURED BY SW SERVICES, INC., PHOENIX, ARIZONA OR EQUAL.
4. THE DEBRIS CAP SHALL BE COMPRISED OF A HOLLOW MEMBER HAVING A CYLINDRICAL OUTER SURFACE, A CLOSURE FOR ONE END AND THREE POINT RESILIENT CONTACT PADS PROJECTING FROM THE OUTER SURFACE. THE CAP SHALL HAVE A FLEXIBLE SKIRT PROVIDING AN OUTWARD SEAL PREVENTING DEBRIS FROM GETTING PAST THE CAP; THE CAP MUST WITHSTAND, WITHOUT SLIPPAGE, A MINIMUM VERTICAL FORCE OF 50 POUNDS, AT A LOADING RATE OF 1.0 IN./ MINUTE. THE CAP SHALL BE MOLDED USING GENERAL ELECTRIC ABS #HIM 4500. THE CAP SHALL HAVE RETAINING PRONGS TO RETAIN A STANDARD LOCATING COIL.

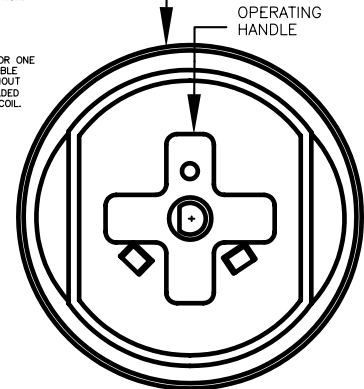
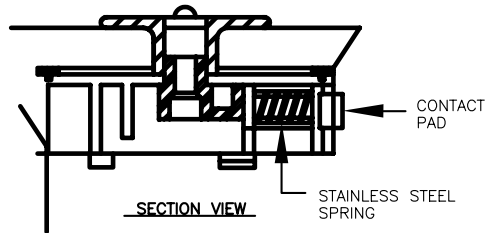
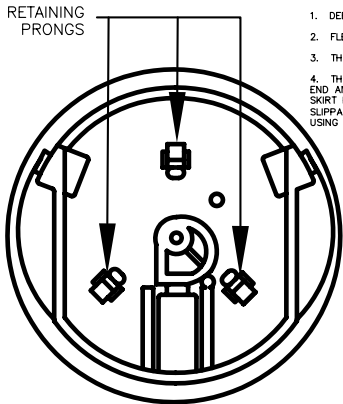

DEBRIS CAP INSTALLATION

DETAIL "6"

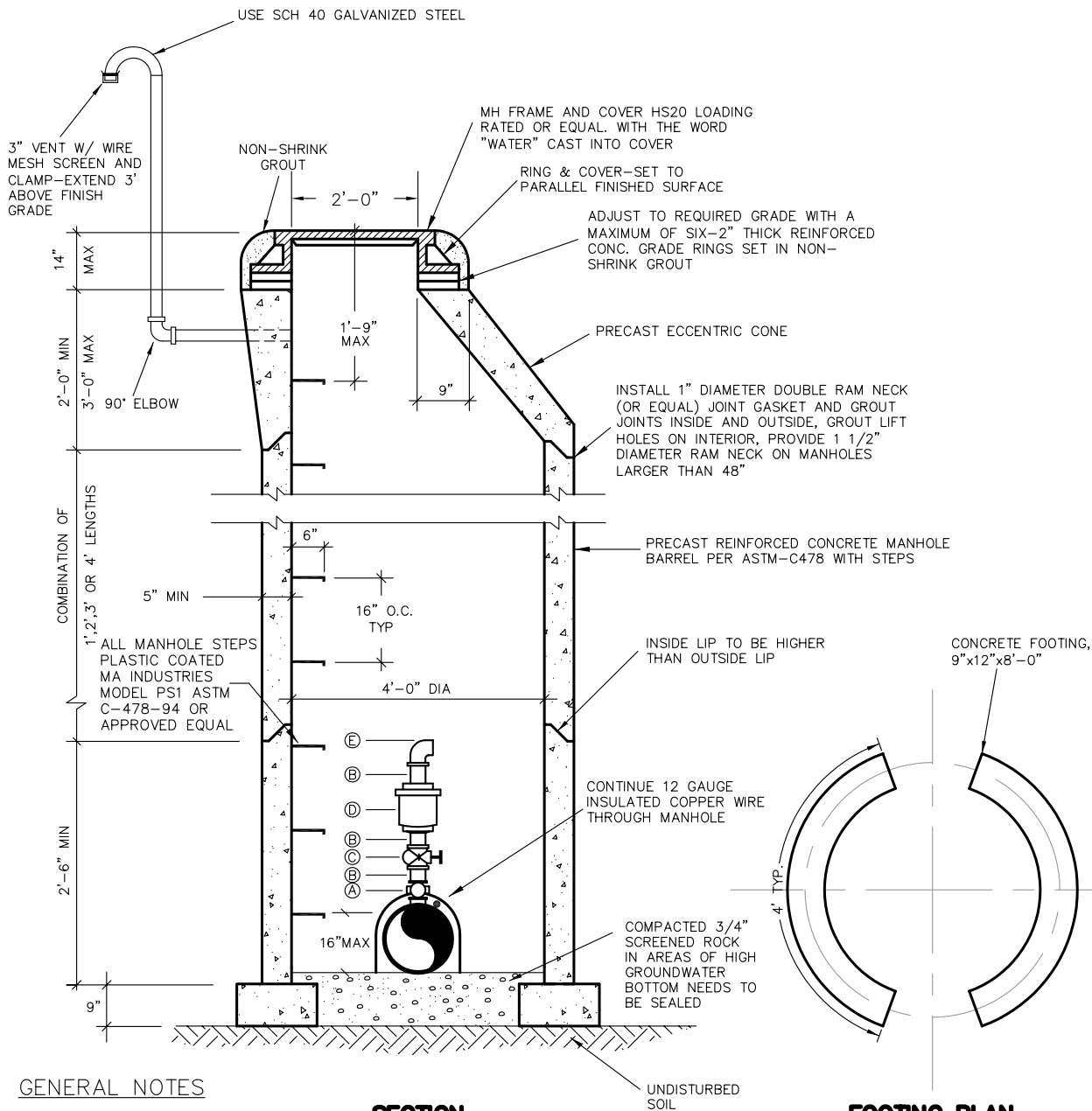

GENERAL NOTES

1. ALL CONCRETE WORK SHALL COMPLY WITH LATEST ACI-318 SPECIFICATIONS
2. AIR VALVE ASSEMBLY LARGER THAN 2" SIZE SHALL BE SPECIALLY DESIGNED AND MEET WATER DEPARTMENT REQUIREMENTS

2" COMBINATION AIR VALVE & MANHOLE

LEGEND

- (A) 2" CORPORATION TAPERED THREADS INLET
- (B) 2" X 4" THREADED BRASS NIPPLE
- (C) 2" THREADED GATE VALVE WITH WHEEL (CRANE OR NIBCO)
- (D) 2" THREADED INLET APCO 144 AIR AND VACUUM RELEASE VALVE
- (E) 2" X 90° PLASTIC ELBOW

DETAIL "7"

DISPERSE LARGE ROCKS IN THIS ZONE PROVIDED ROCKS DO NOT INTERFERE WITH BACKFILL COMPACTION REQUIREMENTS BOULDERS GREATER THAN 18" TO BE REMOVED FROM BACKFILL AND DISPOSED OF OFF SITE.

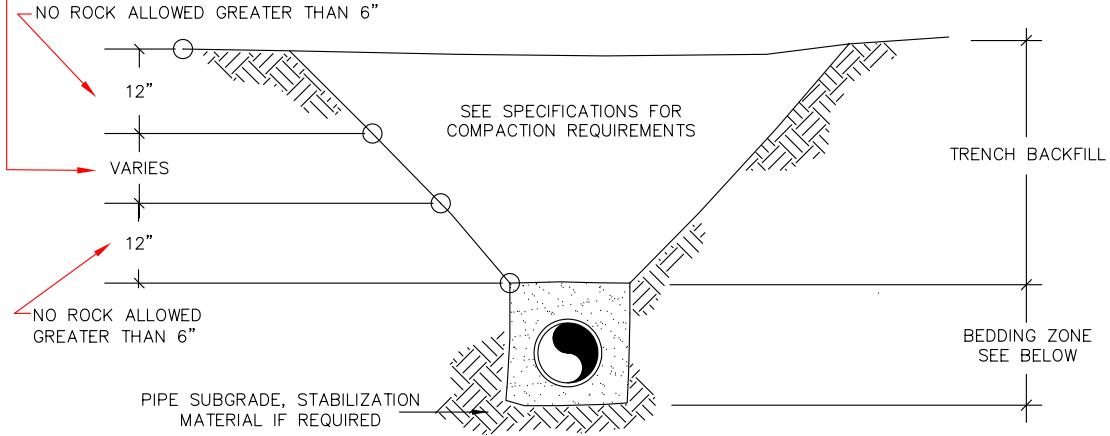

TRENCH ZONES

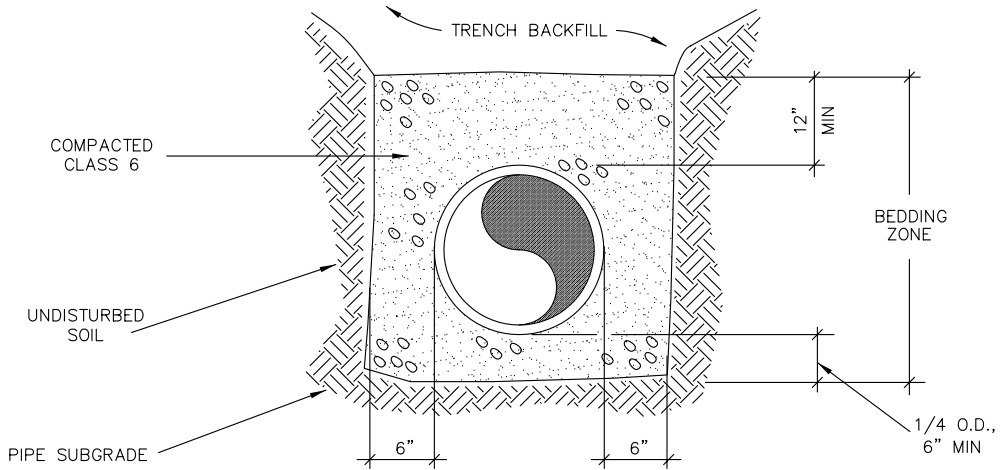

PIPE BEDDING ZONE

WATER PIPE BEDDING

DETAIL "8"

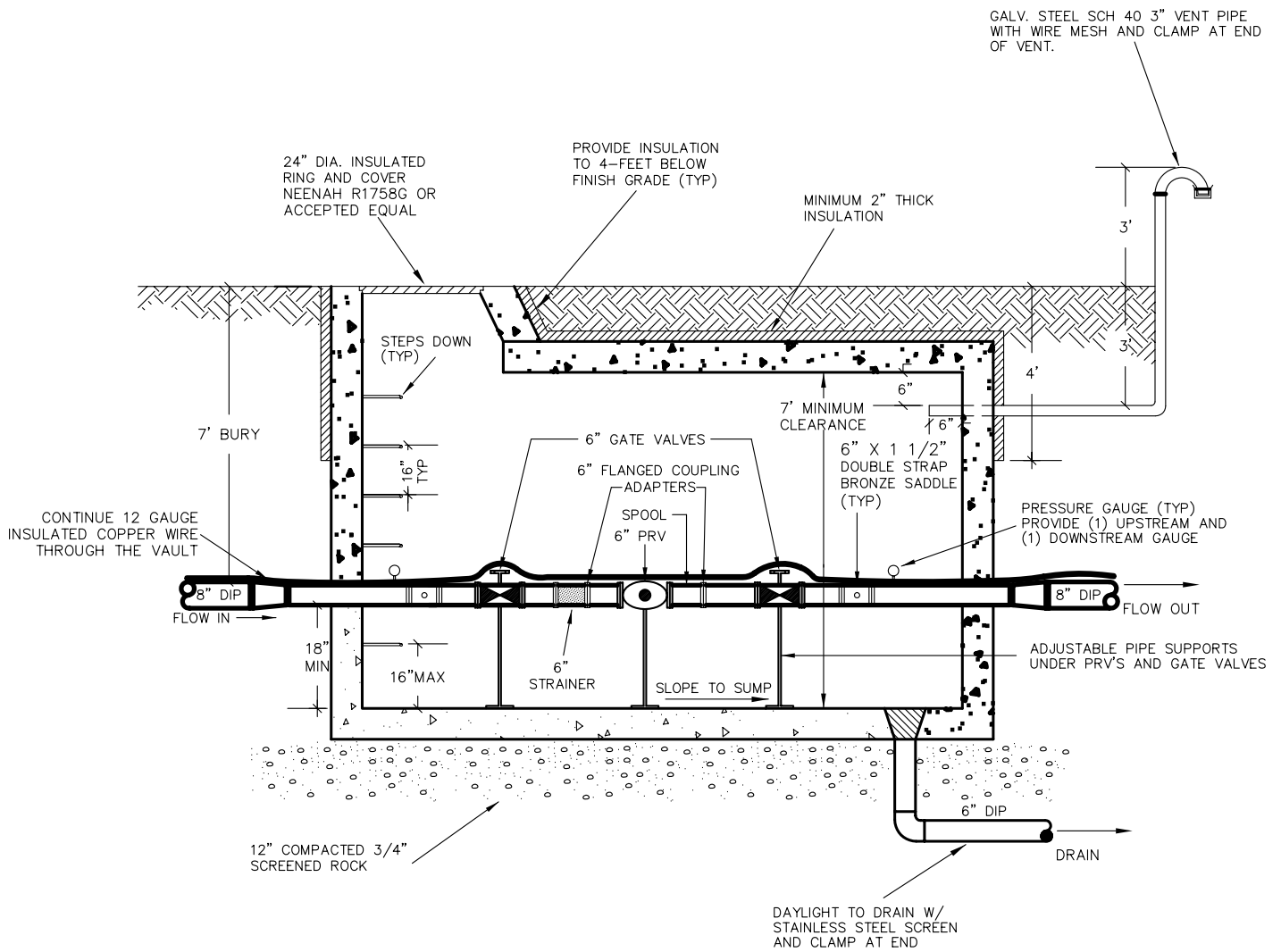

ELEVATION

NOTES

1. VAULT SHALL BE PRECAST CONCRETE AND CAPABLE OF WITHSTANDING HS 20-44 TRAFFIC LOADING CONDITIONS
2. WHERE PIPES PENETRATE WALLS, USE LINK SEAL OR FILL ANNULAR SPACE W/ NON-SHRINK GROUT
3. COAT ALL EXTERIOR VAULT SURFACES WITH BITUMINOUS DAMPROOFING
4. ALL 1 1/2" PIPE SHALL BE BRASS W/ ALL OTHER PIPE AND FITTINGS BEING FLANGED DUCTILE IRON
5. ALL TIE-RODS SHALL BE 3/4" ALL-THREAD OR MEGA-LUGS ON EXTERIOR CONNECTIONS
6. CONTRACTOR SHALL SUBMIT VAULT PIPING SCHEMATIC W/ VAULT DIMENSIONS PRIOR TO ORDERING
7. IT SHALL BE THE OWNER'S RESPONSIBILITY TO VERIFY ALL PRV SIZING AND PRESSURE SETTINGS
SIZES OF PRV'S SHOWN IS FOR ILLUSTRATION PURPOSES ONLY
8. THE DISTRICT SHALL APPROVE FINAL SIZING OF ALL PRV'S AND VALVES

MAIN LINE PRV VAULT

DETAIL "9"

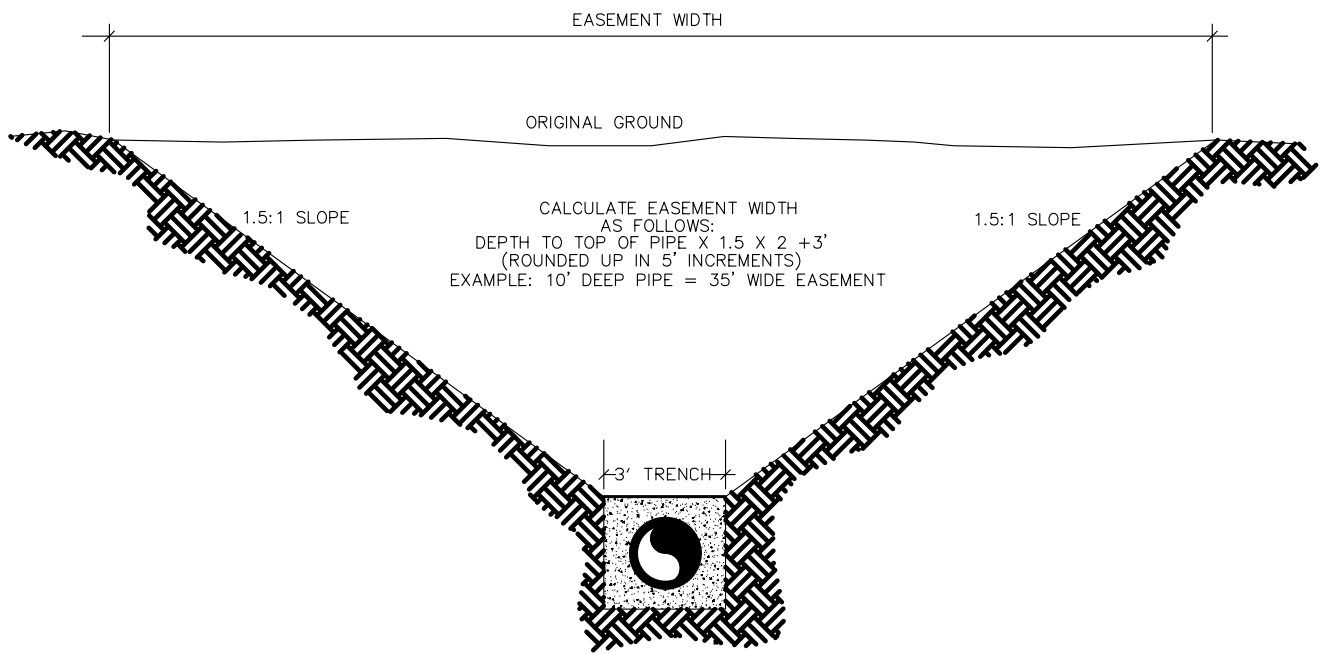

MINIMUM EASEMENT WIDTH

EASEMENT WIDTH

DETAIL "10"

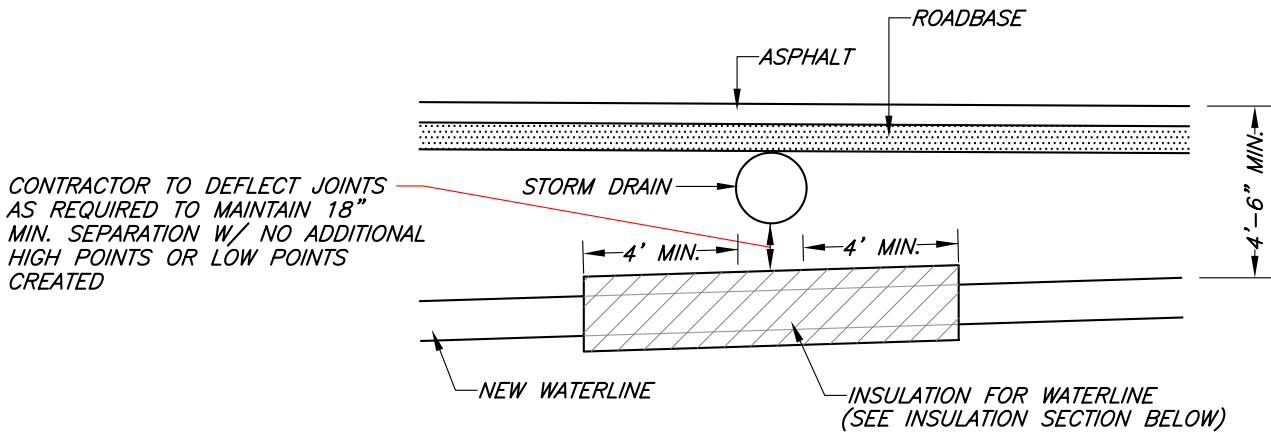

ELEVATION WATERLINE/CULVERT CROSSING

NO SCALE

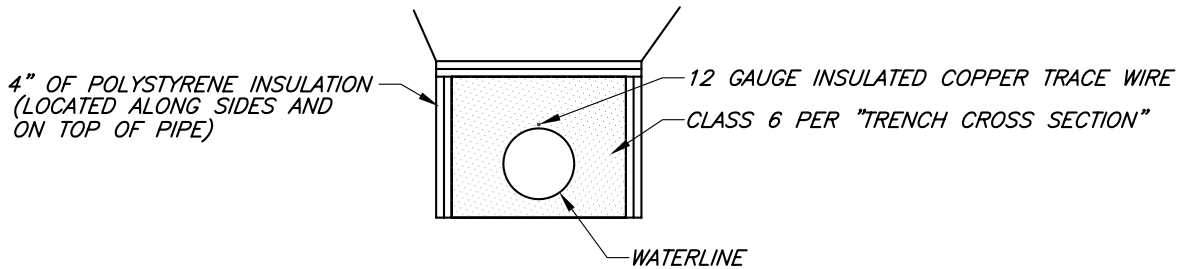

INSULATION SECTION

NO SCALE

INSULATION DETAIL

DETAIL "11"

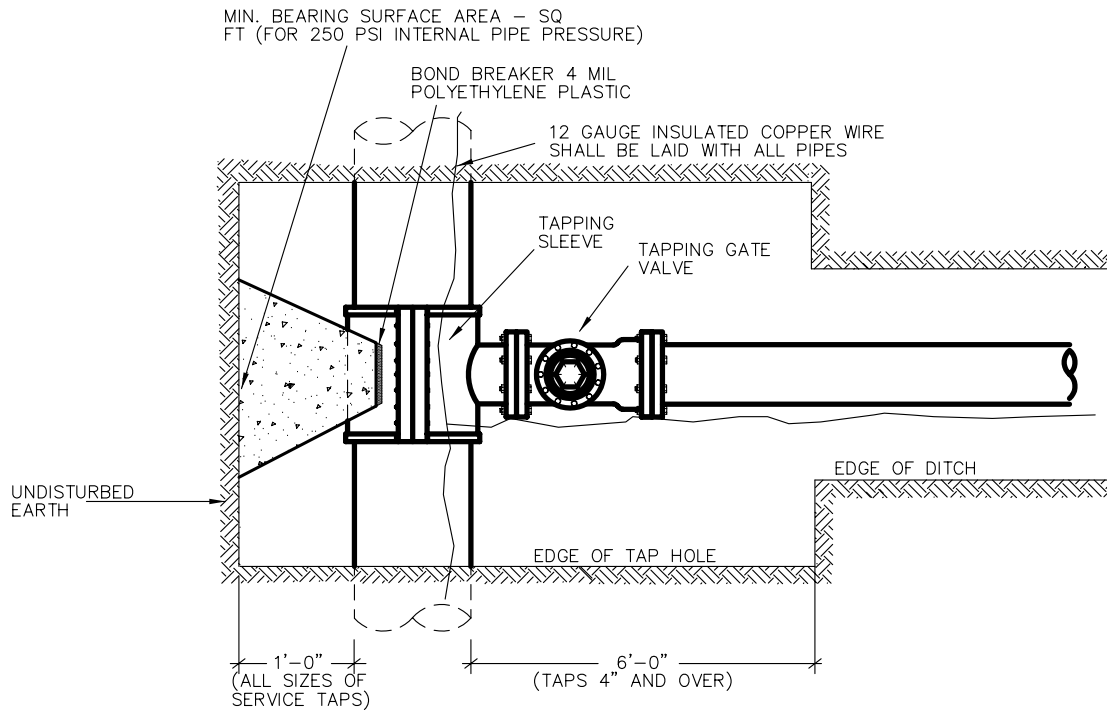

PLAN

12 GAUGE INSULATED COPPER WIRE SHALL BE LAID WITH ALL PIPES

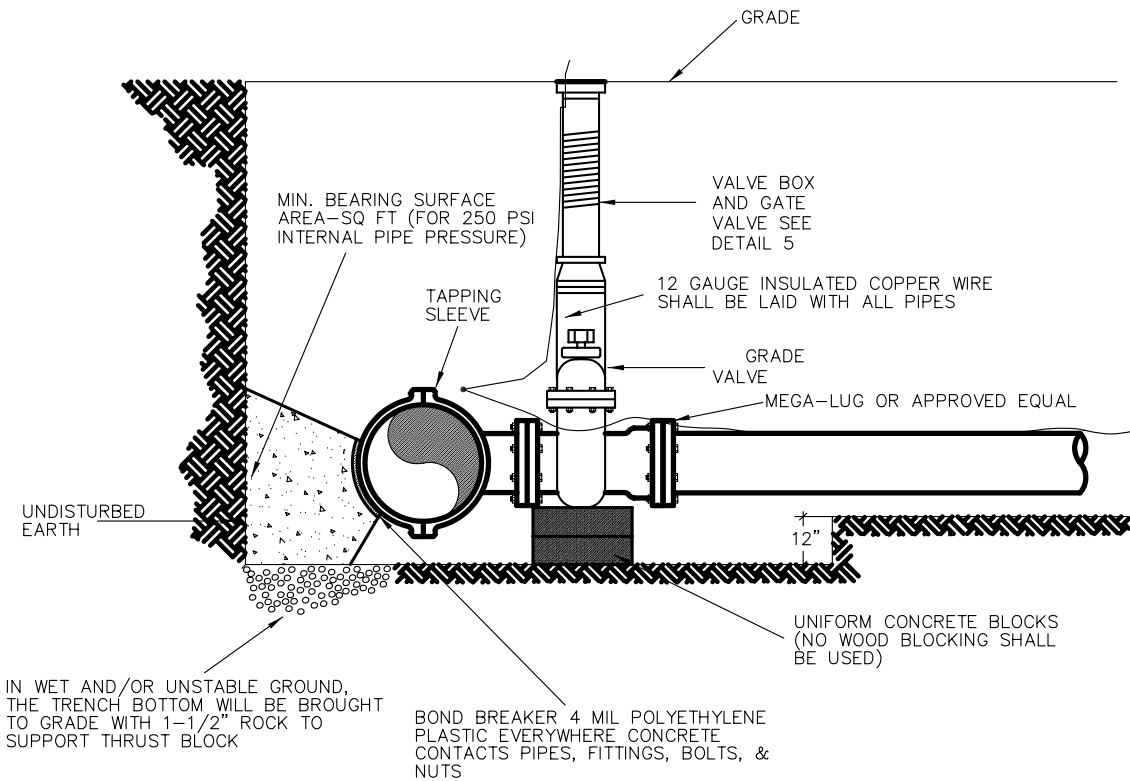

ELEVATION

TAPPING DETAIL

DETAIL "12"

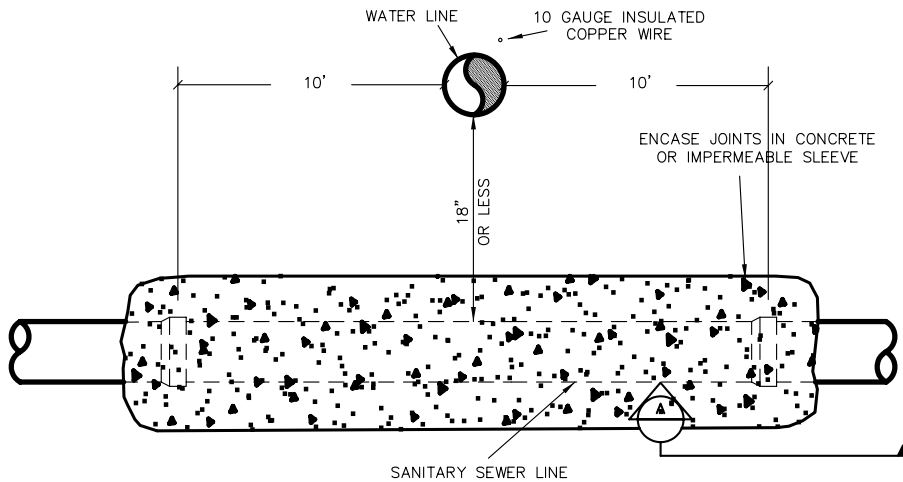

IF WATERLINE IS 18" OR LESS ABOVE SEWER OR IF WATER LINE IS BELOW THE SEWER LINE, INSTALL CONCRETE ENCASEMENT. ENCASEMENT MUST EXTEND UNTIL THE WATER AND SEWER PIPE ARE SEPARATED BY MORE THAN 10 FEET. IN LIEU OF CONCRETE ENCASEMENT C900 PVC PRESSURE PIPE OR YELOMINE PRESSURE PIPE MAY BE SUBSTITUTED.

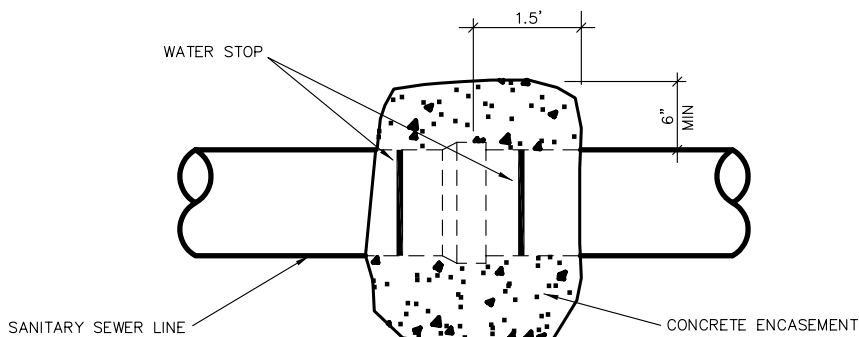

SECTION A

STEEL CASING THICKNESS AND COATING PER REGULATORY AGENCY

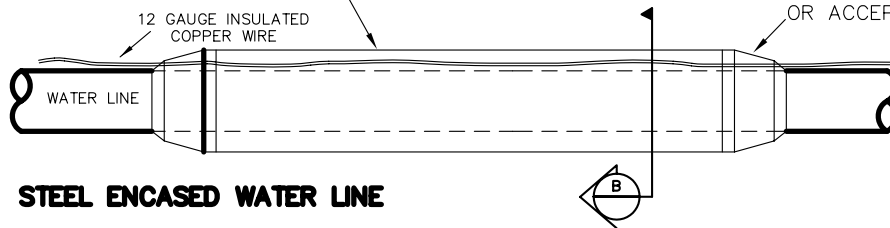

HIGH DENSITY RUBBER CASING WITH 3/4" WIDE STAINLESS STEEL STRAPS. PIPELINE SEAL AND INSULATOR CO. MODEL W OR ACCEPTED EQUAL.

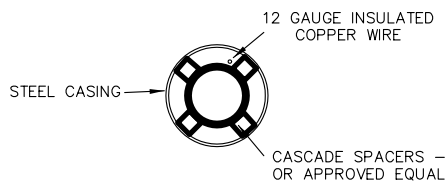

SECTION B

CONCRETE & STEEL PIPE ENCASEMENT

DETAIL "13"

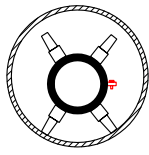

STANDARD

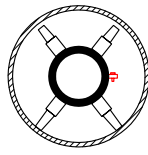

CENTERED

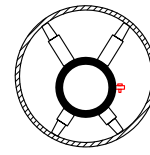

RESTRAINED

BASIC POSITIONS

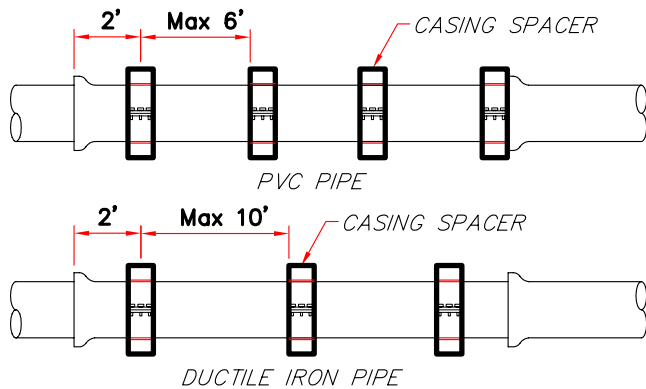

PLACEMENT OF SPACERS ON CARRIER PIPE

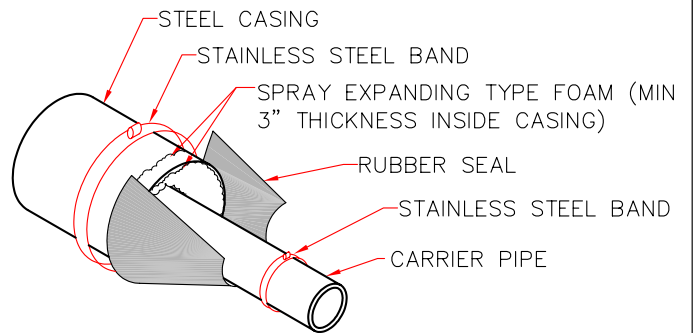

END SEAL

NOTES:

- 1.) **GENERAL:** ONE SPACER SHALL BE PLACED NOT MORE THAN TWO FEET FROM EACH END OF THE CASING SUBSEQUENT SPACERS SHALL BE PLACED AT 10' INTERVALS WITHIN THE CASING.
- 2.) **PVC CARRIER:** ONE SPACER SHALL BE PLACED ON THE SPIGOT END OF EACH SEGMENT AT THE LINE MARKING THE LIMIT OF INSERTION INTO THE BELL. WHEN THE JOINT IS COMPLETE, THE SPACER SHALL BE IN CONTACT WITH THE BELL OF THE JOINT SO THAT THE SPACER PUSHES THE JOINT AND RELIEVES COMPRESSION WITHIN THE JOINT. SUBSEQUENT SPACERS SHALL BE PLACED AT 6' INTERVALS.
- 3.) CARRIER PIPE SHALL BE INSERTED WITHIN CASING BY USE OF MODEL CCS STAINLESS STEEL CASING SPACERS AS MANUFACTURED BY CASCADE WATERWORKS MFG. CO. OF YORKVILLE, IL OR APPROVED EQUAL BY DISTRICT ENGINEER.
- 4.) ALL PIPE JOINTS LOCATED WITHIN THE CASING AND THE FIRST JOINT EITHER SIDE OF CASING SHALL BE RESTRAINED BY USING SNAP LOCK TYPE GASKETS MANUFACTURED BY US PIPE OR APPROVED EQUAL BY DISTRICT ENGINEER. ALL RESTRAINED PIPE IS TO BE TYPE TYTON-JOINT AS MANUFACTURED BY US PIPE OR APPROVED EQUAL BY DISTRICT ENGINEER. ALL RESTRAINED PIPE IS TO BE INSTALLED USING THE RESTRAINED POSITION OF CARRIER INSTALLATION.
- 5.) CONTRACTOR TO INSTALL PER SPECIFICATIONS SUPPLIED BY CASCADE WATERWORKS MANUFACTURING COMPANY OR APPROVED EQUAL BY DISTRICT ENGINEER.

PIPE ENCASEMENT DETAIL

NTS

PIPE ENCASEMENT DETAIL

DETAIL "14"

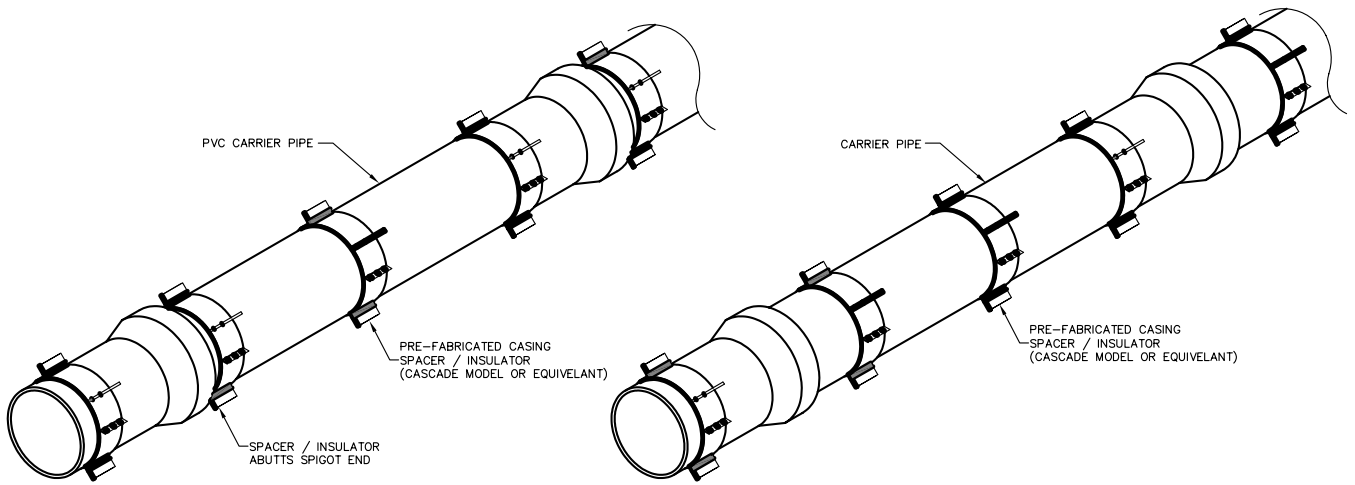

GENERAL NOTES:

1. ONE SPACER SHALL BE PLACED NOT MORE THAN TWO FEET FROM EACH END OF THE CASING. SUBSEQUENT SPACERS SHALL BE PLACED AT 10' INTERVALS WITHIN CASING
2. PVC CARRIER: ONE SPACER SHALL BE PLACED ON THE SPIGOT END OF EACH SEGMENT AT THE LINE MARKING THE LIMIT OF INSERTION INTO THE BELL. WHEN THE JOINT IS COMPLETE, THE SPACER SHALL BE IN CONTACT WITH THE BELL OF THE JOINT SO THAT THE SPACER PUSHES THE JOINT AND RELIEVES COMPRESSION WITHIN THE JOINT. SUBSEQUENT SPACERS SHALL BE PLACED AT 6" INTERVALS

RECOMMENDED PLACEMENT ON PVC PIPE

RECOMMENDED PLACEMENT ON OTHER PIPE

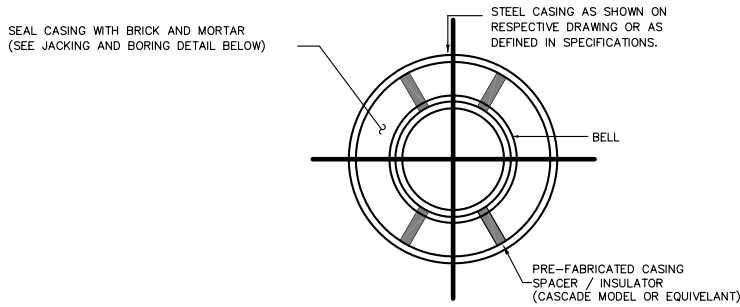

SECTION "A"

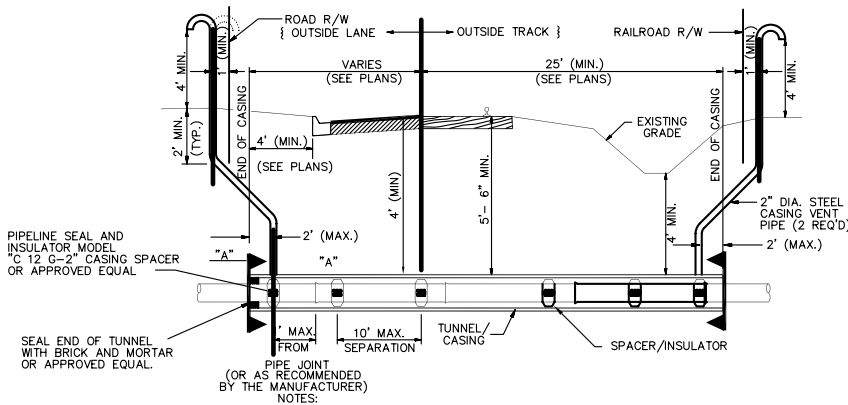

- NOTES:
1. WATER MAIN TO BE RESTRAINED THROUGH TUNNEL / CASING.
 2. PIPELINE SHALL BE PROMINENTLY MARKED AT RAILROAD RIGHT-OF-WAY BY SIGNS WORDED, "HIGH PRESSURE MAIN BURIED BELOW".
 3. VENT PIPES SHALL BE FITTED WITH SCREENED DOWN-TURNED ELBOWS.
 4. VENT PIPES SHALL BE INSTALLED ONLY IF TUNNEL / CASING IS NOT FILLED.

JACK AND BORE DETAILS FOR CROSSINGS

N.T.S.

DETAIL "15"

PROVIDE 3" GALV. STEEL VENT
W/ WIRE MESH AND STEEL CLAMP-
VENT TO EXTEND 3' ABOVE FINISH GRADE

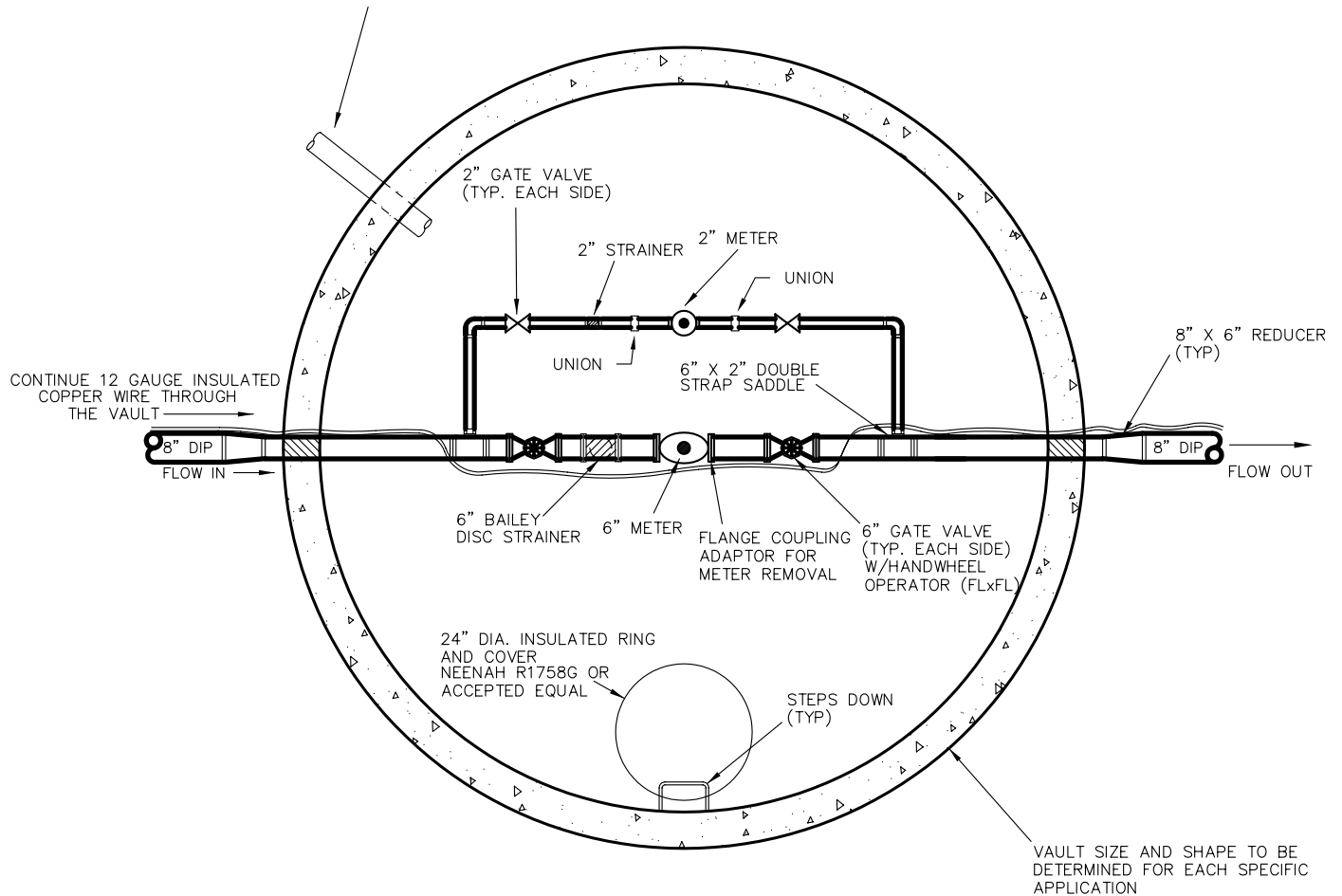

PLAN

NOTES

1. VAULT SHALL BE PRECAST CONCRETE AND CAPABLE OF WITHSTANDING HS 20-44 TRAFFIC LOADING CONDITIONS
2. WHERE PIPES PENETRATE WALLS, USE LINK SEAL OR FILL ANNULAR SPACE W/ NON-SHRINK GROUT
3. COAT ALL EXTERIOR VAULT SURFACES WITH BITUMINOUS DAMPROOFING
4. ALL 2" PIPE SHALL BE BRASS W/ ALL OTHER PIPE AND FITTINGS BEING FLANGED DUCTILE IRON
5. ALL TIE-RODS SHALL BE 3/4" ALL-THREAD OR MEGA-LUGS ON EXTERIOR CONNECTIONS
6. CONTRACTOR SHALL SUBMIT VAULT PIPING SCHEMATIC W/ VAULT DIMENSIONS TO DISTRICT PRIOR TO ORDERING MATERIALS OR EQUIPMENT

WATER METER

DETAIL "16"

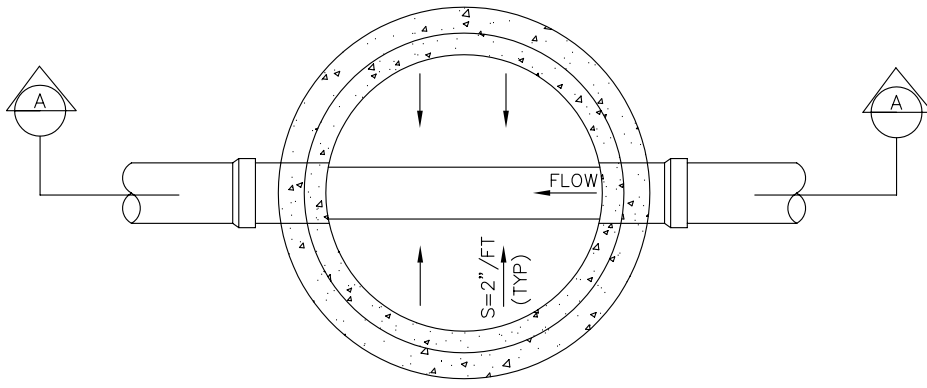

PLAN

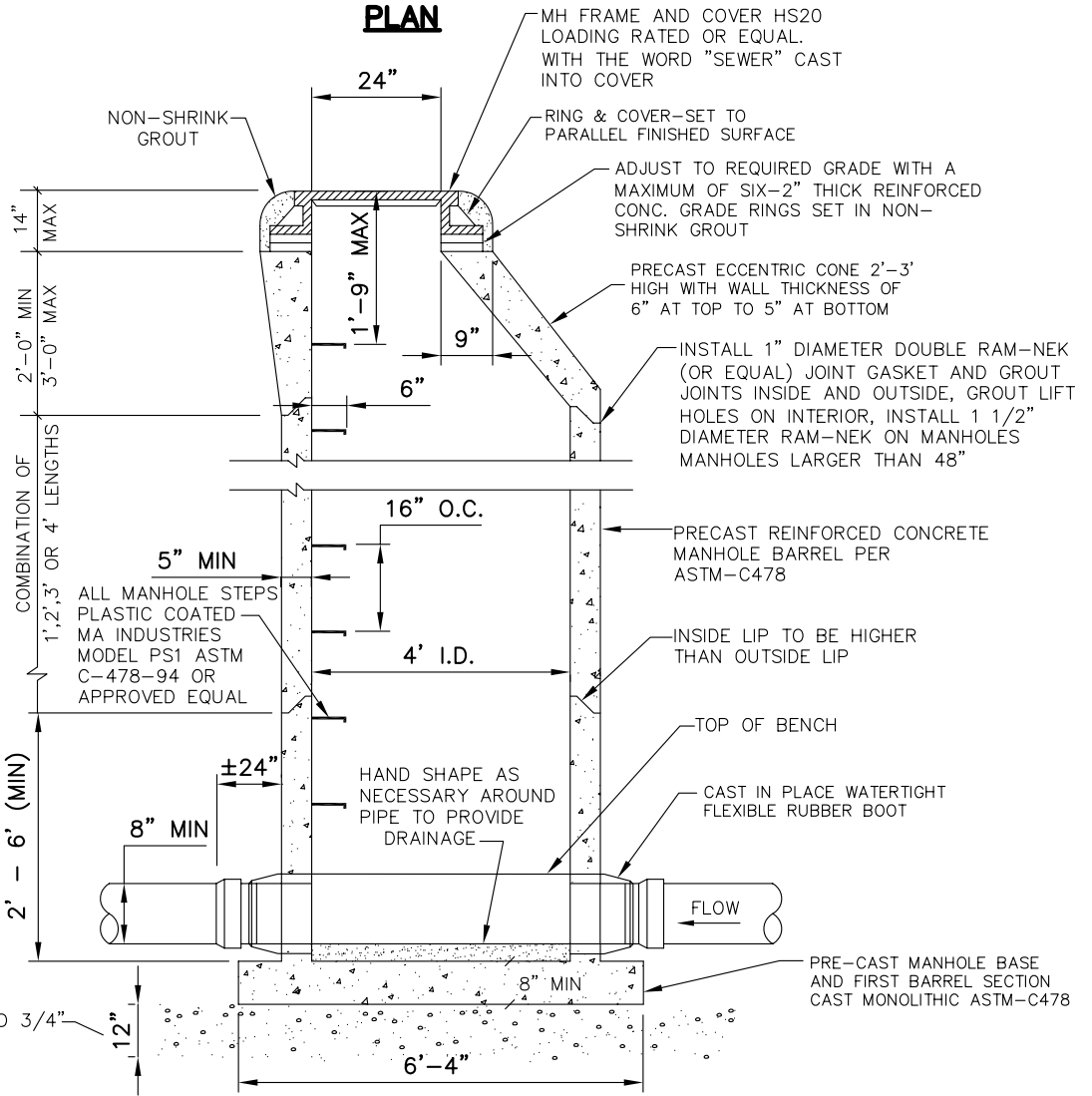

SECTION A

STANDARD MANHOLE

- GENERAL NOTE
1. ALL CONCRETE WORK SHALL COMPLY WITH LATEST CI-318 SPECIFICATIONS
 2. USE 5' I.D. WHEN PIPE SIZE 15" - 24".

DETAIL "A"

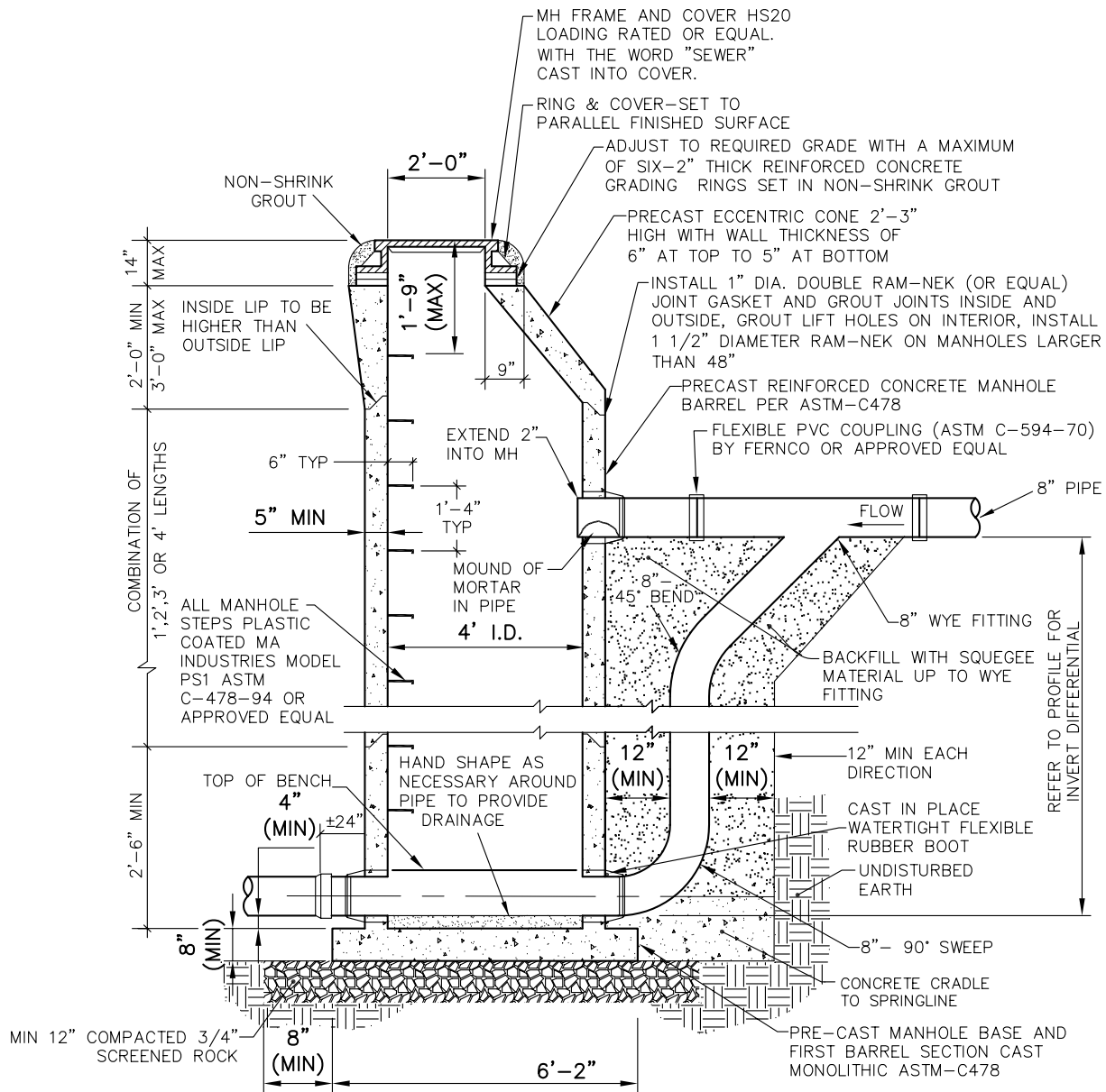

DROP MANHOLE

GENERAL NOTES:

1. ALL CONCRETE WORK SHALL COMPLY WITH LATEST CI-318 SPECIFICATIONS
2. USE 5' I.D. WHEN PIPE SIZE 15" - 24"

DETAIL "B"

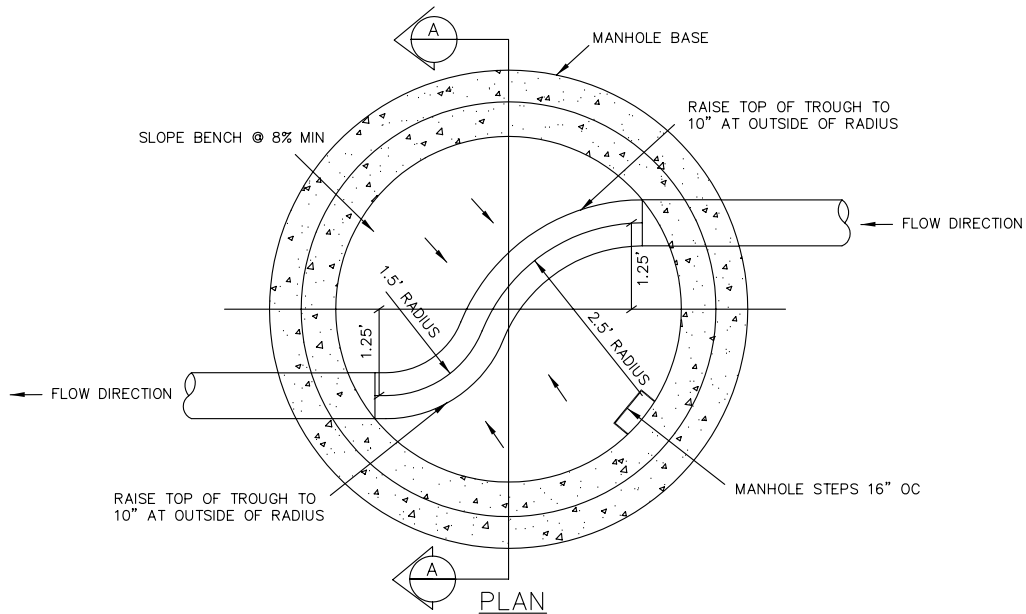

5' INSIDE DIA MANHOLE
 PRECAST REINFORCED
 CONCRETE MANHOLE BARREL
 PER ASTM-C478

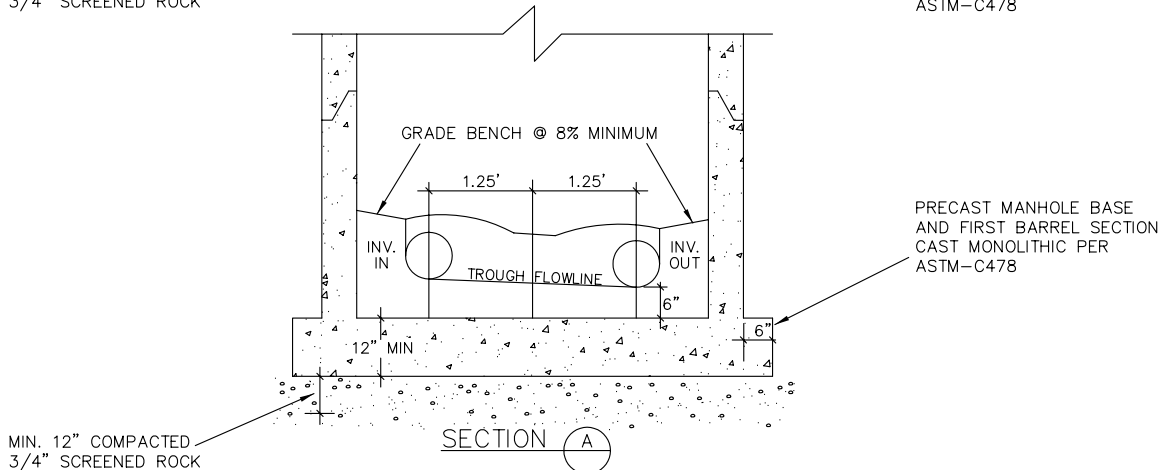
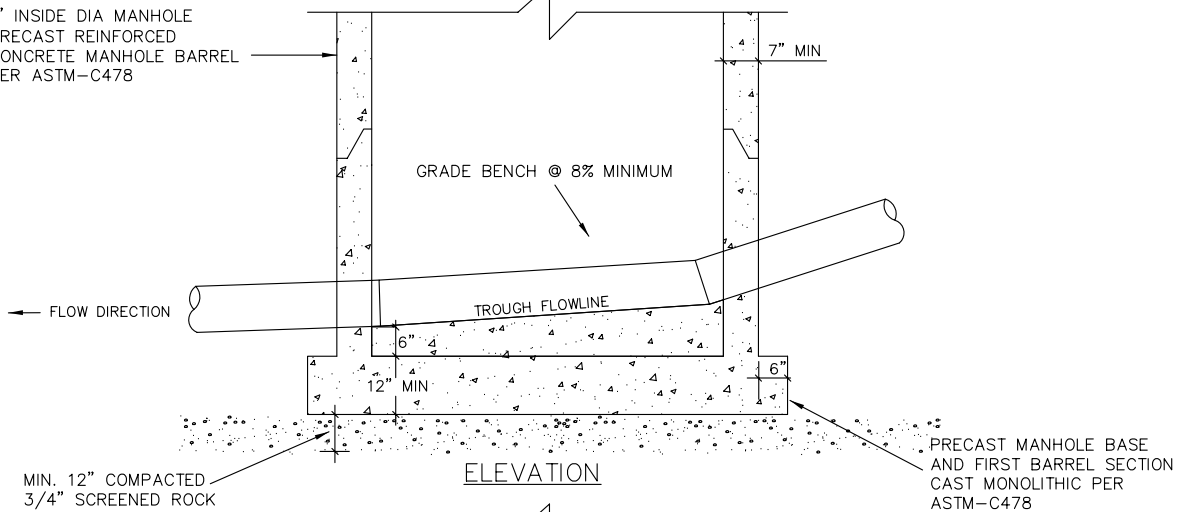

SET ECCENTRIC MANHOLE RIM SECTION SO THAT THE RIM IS AWAY FROM THE EDGE OF ASPHALT AS MUCH AS POSSIBLE.

**ENERGY DISSIPATOR
 MANHOLE**

DETAIL "C"

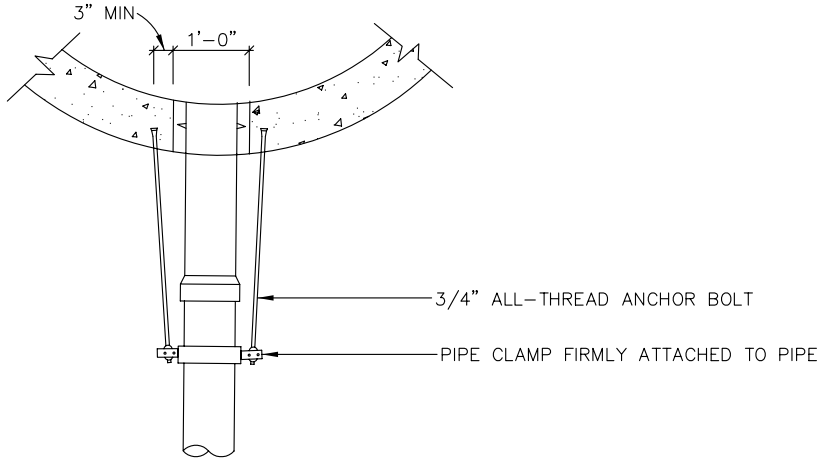

TOP VIEW

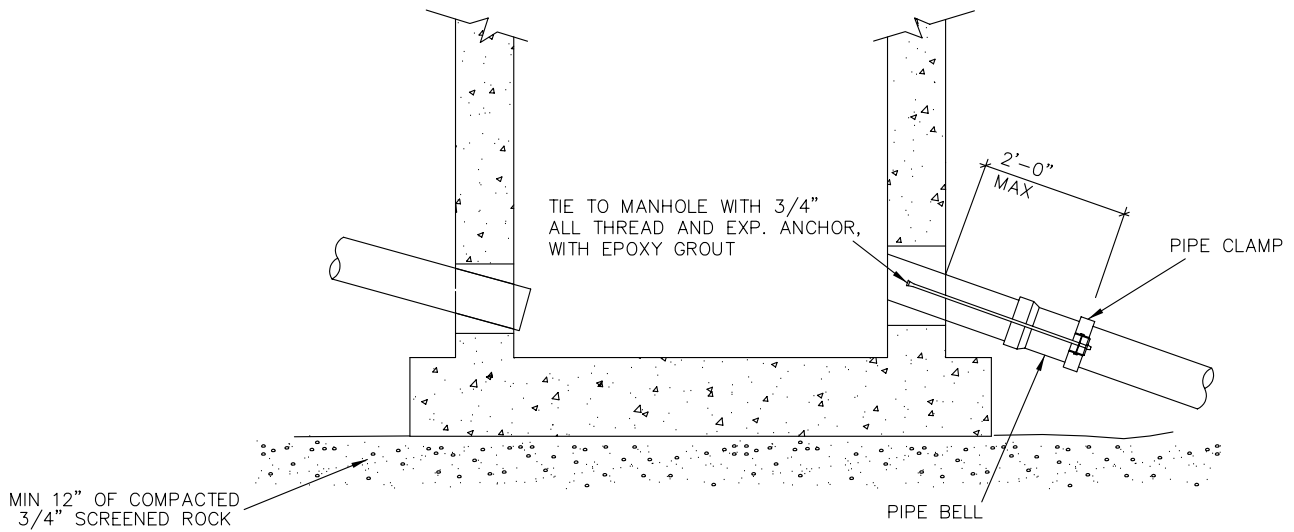

ELEVATION

NOTE: ANCHOR MANHOLES ARE REQUIRED WHERE PIPE SLOPE EXCEEDS 20% EXITING THE MANHOLE ONLY

ANCHOR MANHOLE

DETAIL "D"

DISPERSE LARGE ROCKS IN THIS ZONE PROVIDED ROCKS DO NOT INTERFERE WITH BACKFILL COMPACTION REQUIREMENTS BOULDERS GREATER THAN 18" TO BE REMOVED FROM BACKFILL AND DISPOSED OF OFF SITE.

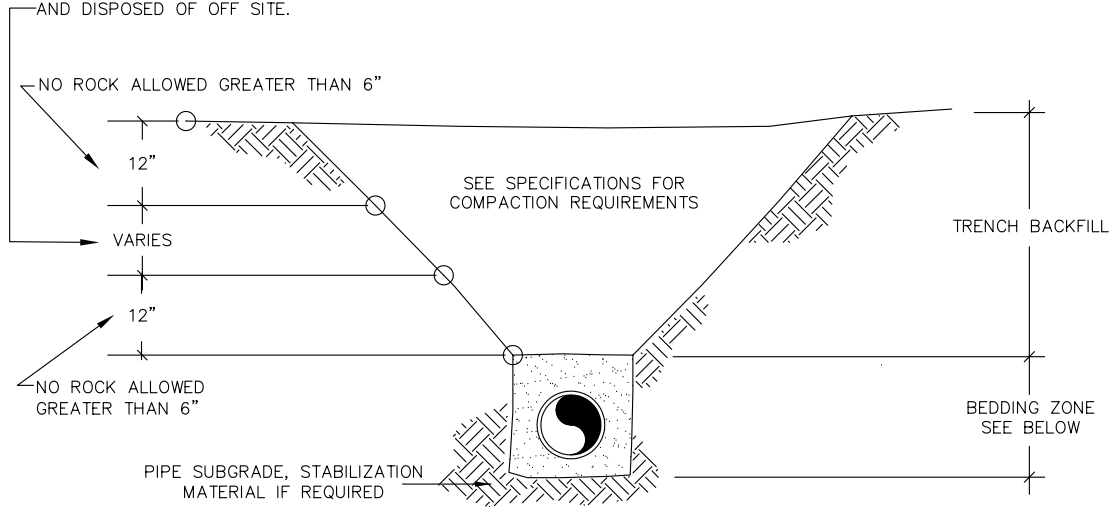

TRENCH ZONES

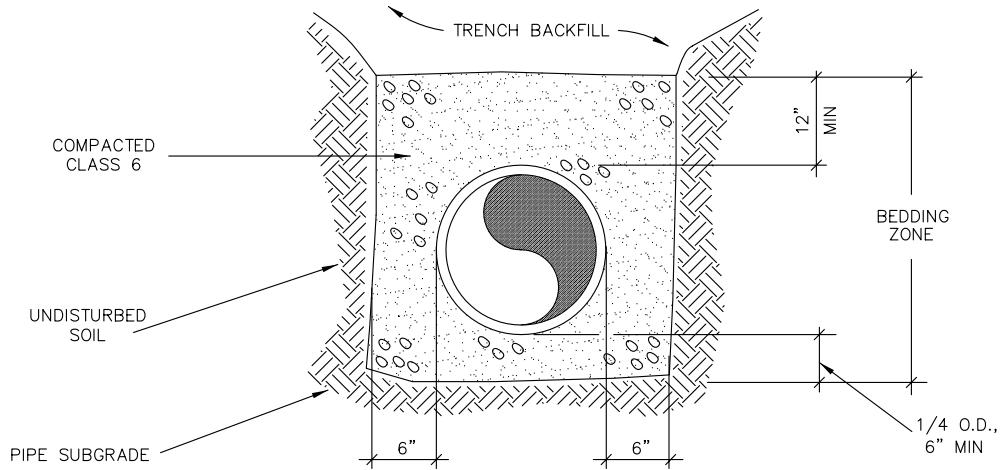

PIPE BEDDING ZONE

SEWER PIPE BEDDING

DETAIL "E"

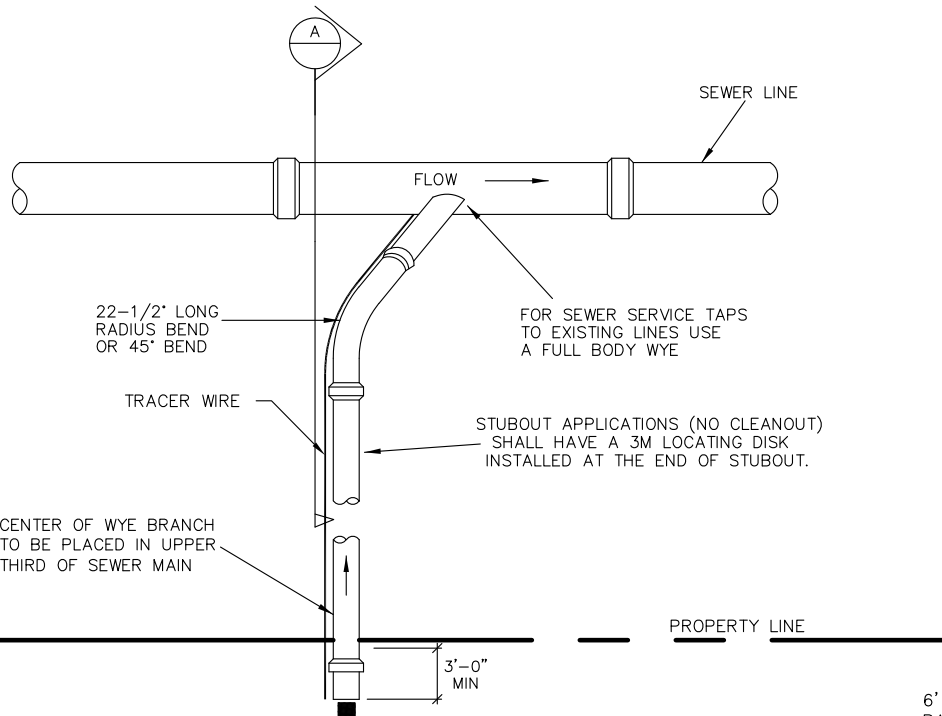

PLAN

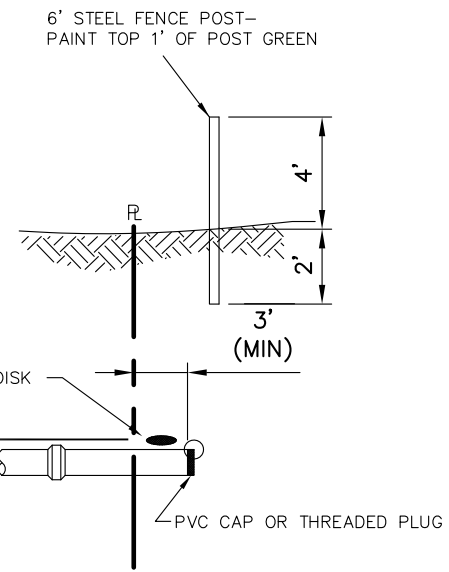

SECTION A

SEWER SERVICE CONNECTION

NOTES:

1. MINIMUM SEPARATION BETWEEN TAPS SHALL BE 18"
2. BACKFILL UNDER WYE TO BE CLASS 6 AGGREGATE BASE COURSE. 95% COMPACTION DENSITY PER ASTM D-698.

DETAIL "F"

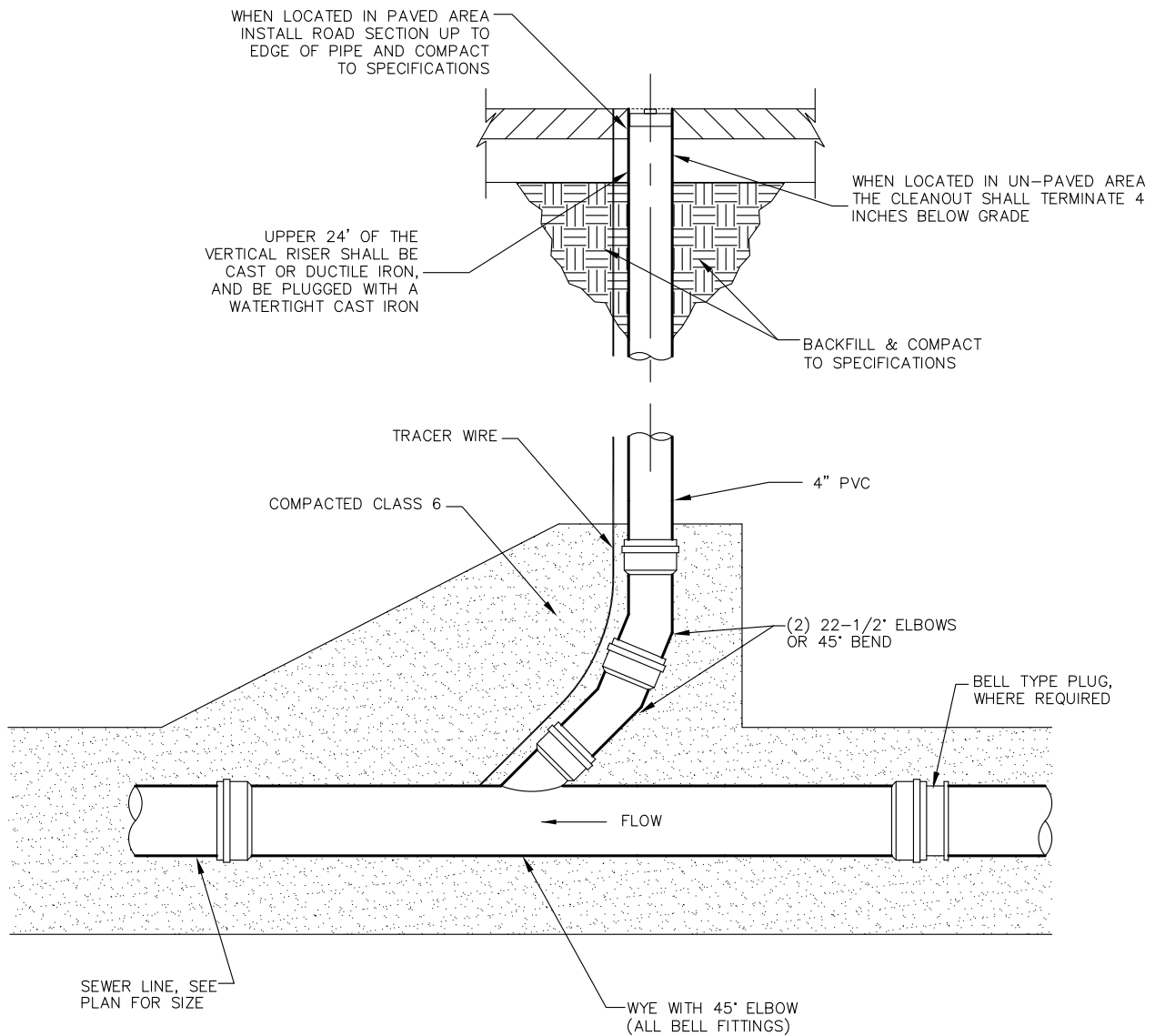

SEWER CLEAN-OUT

NOTES:

1. FOR SKIWAY APPLICATIONS WHERE MANHOLE AND RINGS ARE USED TO COVER CLEANOUT, 3M LOCATING DISK SHALL ALSO BE INSTALLED 1' TO 2' BELOW MANHOLE RING AND COVER

DETAIL "G"

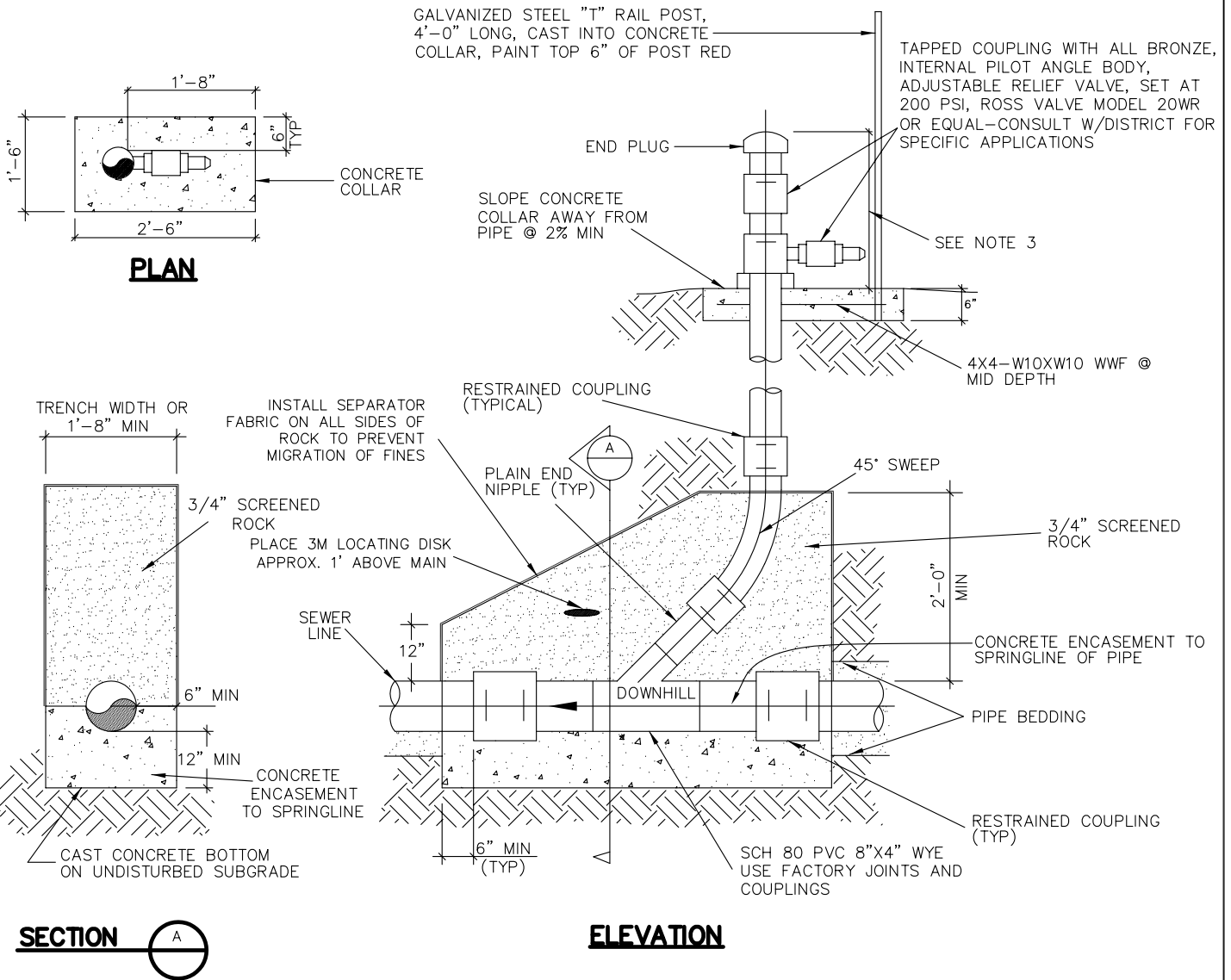

PRESSURE CLEAN-OUT

NOTES:

1. ENTIRE WYE SECTION AND ADJACENT COUPLINGS TO BE ENCASED IN CONCRETE
2. ENTIRE PRESSURE CLEANOUT SHALL BE PRESSURE RATED AT 200 PSIG MINIMUM
3. MAINTAIN MINIMUM HEIGHT REQUIRED FOR REMOVAL OF END PLUG FITTING ONLY
4. PRESSURE CLEANOUTS ARE REQUIRED AT THE BOTTOM MOST LOCATIONS WHERE PRESSURES MAY EXCEED BURSTING PRESSURE OF THE PIPE
5. FOR SKIWAY APPLICATIONS WHERE MANHOLE AND RINGS ARE USED TO COVER CLEANOUT, 3M LOCATING DISK SHALL ALSO BE INSTALLED 1' TO 2' BELOW MANHOLE RING AND COVER.

DETAIL "H"

CONSTRUCT HAMMERHEAD OR 90° SIDEARM TURN-AROUND
 AT THE END OF ALL DEAD END SEWER LINES.
 SEE TURN AROUND DETAIL

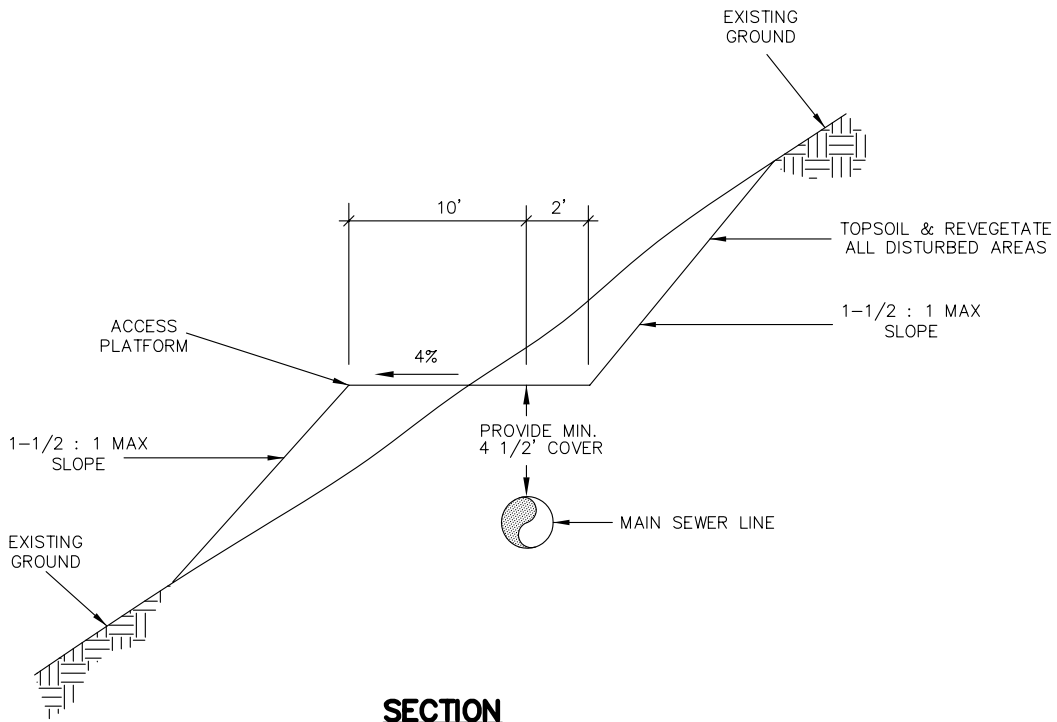

SECTION

**SEWER MAINTENANCE
 ACCESS**

NOTES:

1. THE CONTRACTOR SHALL GRADE ALL OFFROAD SEWER LINE TRENCHES TO PROVIDE ACCESS PLATFORM.
2. ACCESS PLATFORMS SHALL BE GRADED TO MATCH ROAD GRADES TO PROVIDE VEHICULAR ACCESS AT ALL ROAD AND PLATFORM ACCESS INTERSECTIONS. MAXIMUM GRADE FOR BACKLOT ACCESS SHALL BE 7%.

DETAIL "I"

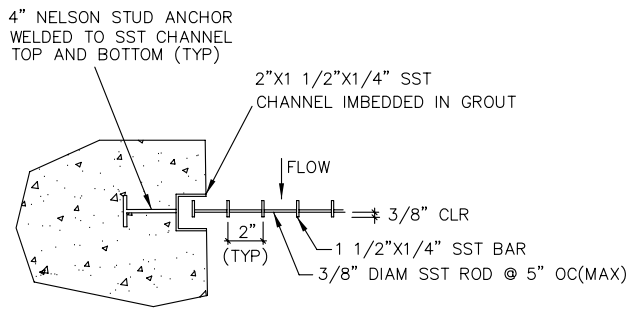

SECTION D

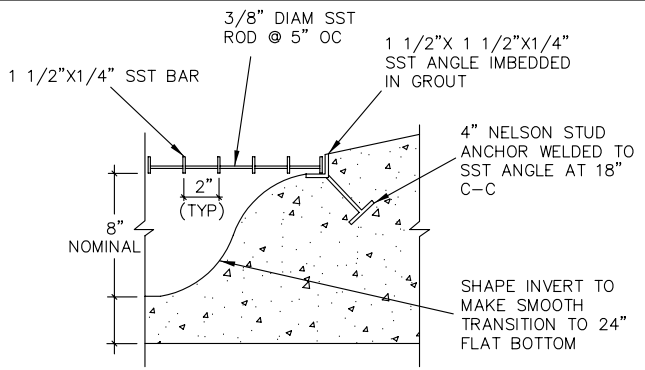

SECTION C

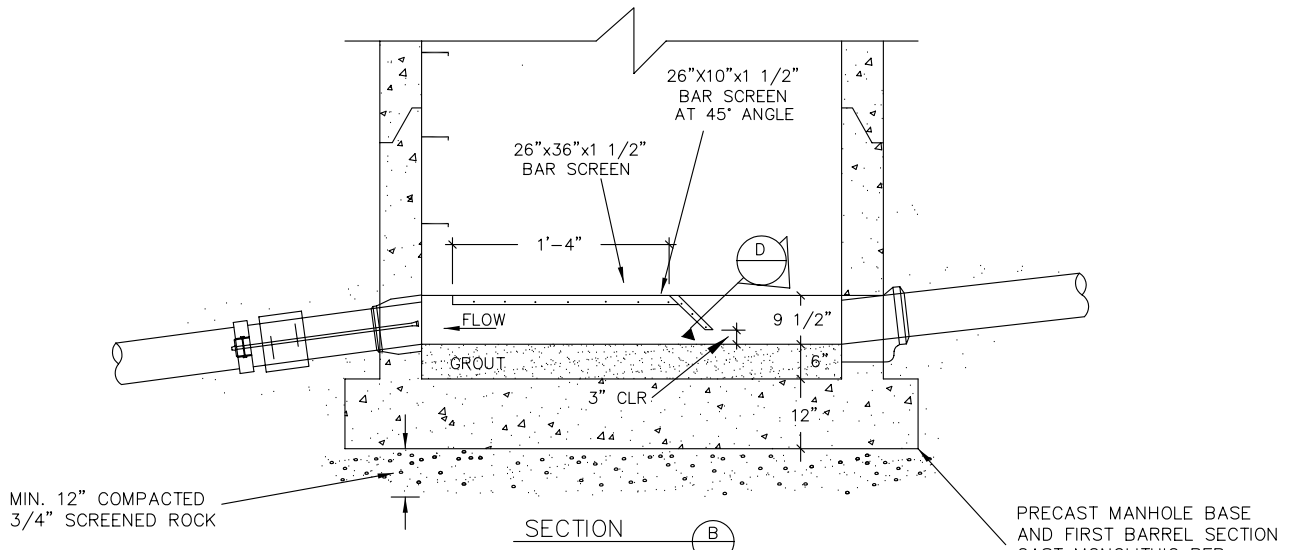

SECTION B

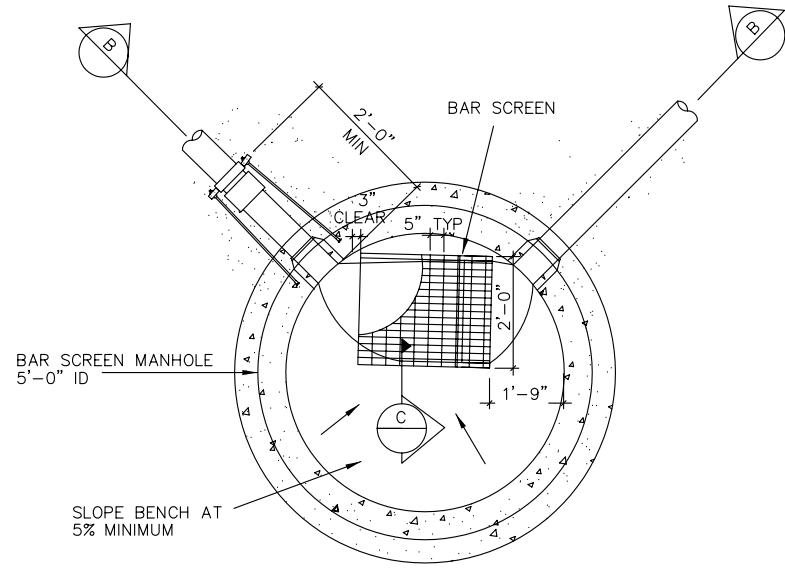

PLAN

- NOTES:
1. USE TYPICAL BAR SCREEN MANHOLE OR A DISTRICT APPROVED EQUAL
 2. THE DISTRICT WILL NOT ALLOW THREE-WAY BAR SCREEN MANHOLES

**90 BAR SCREEN
MANHOLE**

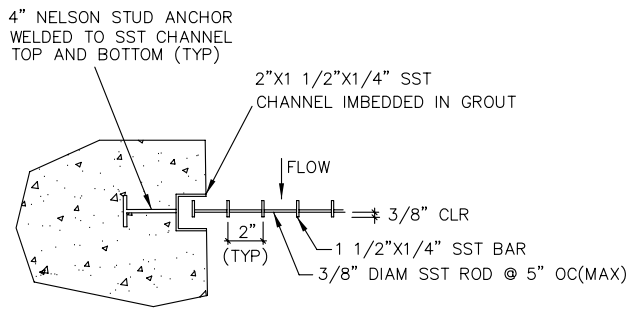

SECTION D

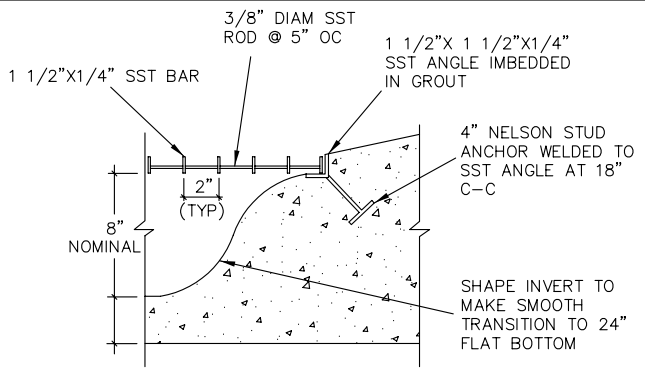

SECTION C

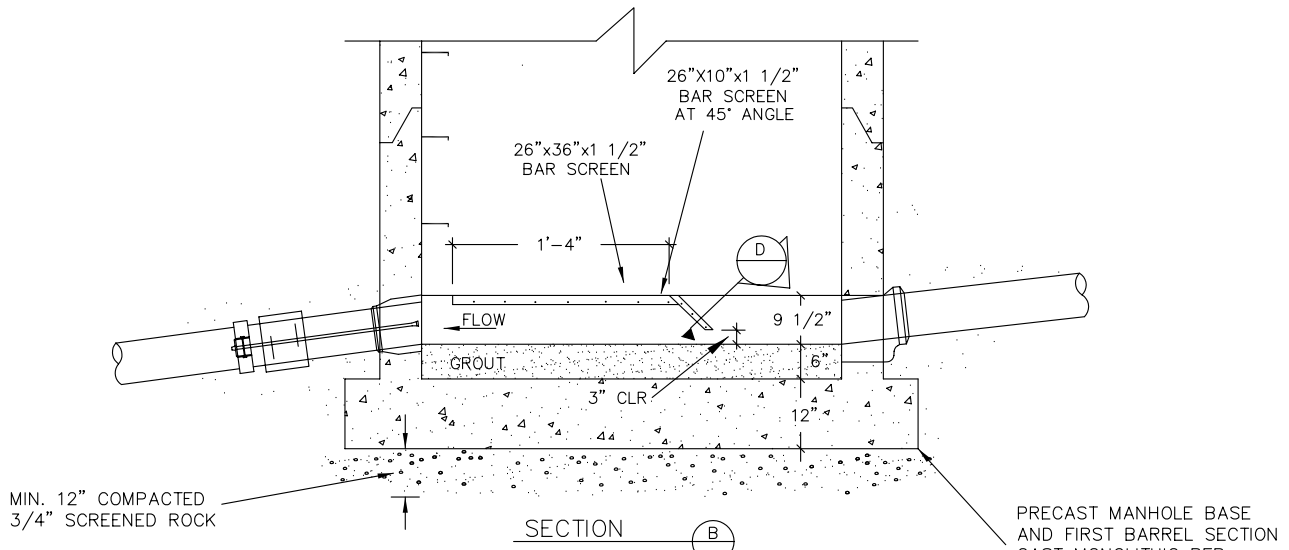

SECTION B

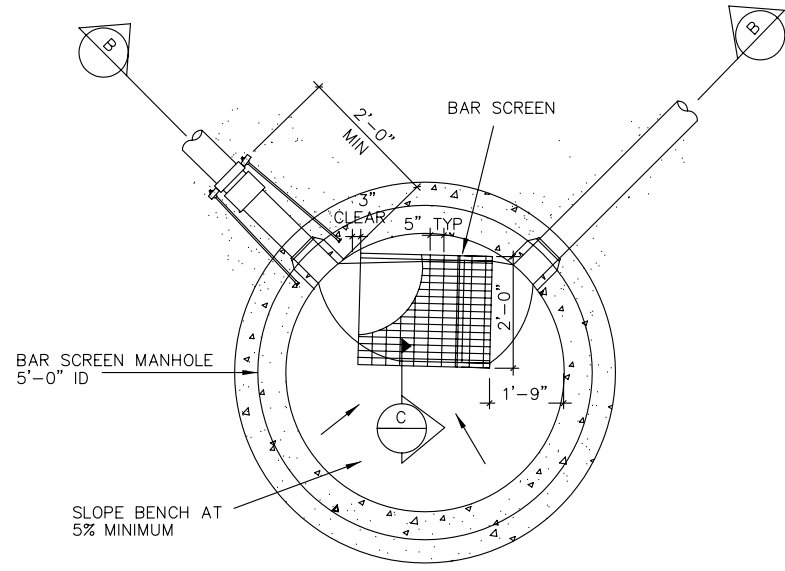

PLAN

- NOTES:
1. USE TYPICAL BAR SCREEN MANHOLE OR A DISTRICT APPROVED EQUAL
 2. THE DISTRICT WILL NOT ALLOW THREE-WAY BAR SCREEN MANHOLES

90 BAR SCREEN MANHOLE

